

**ENDOSCOPY CENTER OF WESTERN NEW YORK**

**SITE INFORMATION**

**Alternate contact:** Ann Sariego

**Phone:** (917) 509-6978

**Email address:** Annie.Sariego@scasurgery.com

**Type of Application:** Establishment  Construction  Administrative  Limited

**Total Project Cost:**

\$ 5,960,171

**Operator Information – Main Site:**

Operator: Endoscopy Center of Western New York, LLC (Op Cert #: 1421202R)

Site: 60 Maple Road, Williamsville (Erie County) New York 14221

PFI: 6629

**Project Site Information – Extension Clinic Site:**

Operator: Endoscopy Center of Western New York, LLC (Op Cert #: 1421202R)

Site Name: Endoscopy Center of Western New York – Orchard Park

Site: 250 Windward Road, Suite 140, Orchard Park (Erie County), New York 14127

PFI: TBD

**Site Proposal Summary (maximum of 1,000 characters):**

Endoscopy Center of Western New York, LLC (ECWNY) operates a single-specialty (gastroenterology) freestanding ambulatory surgery center located at 60 Maple Road, Williamsville (Erie County), New York 14221 (the Center). ECWNY is submitting this Full Review Certificate of Need (C.O.N.) Application seeking approval to: (1) certify and construct a single-specialty (gastroenterology) extension clinic of the Center to be located at 250 Windward Road, Suite 140, Orchard Park (Erie County), New York 14127; and (2) change the Center’s ownership and create two (2) ownership divisions within the Center.

**Modify Name/Address:** Adding new extension clinic – see Project Site above

**Beds:** N/A

**Services at Main Site:**

	Existing	Add	Remove	Proposed
AMBULATORY SURGERY				
SINGLE-SPECIALTY (Gastroenterology) - FASC	<input checked="" type="checkbox"/>	<input type="checkbox"/>	<input type="checkbox"/>	<input checked="" type="checkbox"/>

**Proposed Services at Extension Clinic:**

	Existing	Add	Remove	Proposed
AMBULATORY SURGERY				
SINGLE-SPECIALTY (Gastroenterology) - FASC	<input type="checkbox"/>	<input checked="" type="checkbox"/>	<input type="checkbox"/>	<input checked="" type="checkbox"/>

**Remove Site:** N/A

## **ENDOSCOPY CENTER OF WESTERN NEW YORK**

Endoscopy Center of Western New York, LLC (ECWNY) operates a single-specialty (gastroenterology) freestanding ambulatory surgery center (FASC) located at 60 Maple Road, Williamsville (Erie County), New York 14221 (the Center). ECWNY is submitting this Full Review Certificate of Need (C.O.N.) Application seeking approval to:

1. Certify and construct a single-specialty (gastroenterology) extension clinic of the Center to be located at 250 Windward Road, Suite 140, Orchard Park (Erie County), New York 14127; and
2. Change the Center's ownership and create two (2) ownership divisions within the Center.

### **The Extension Clinic**

The Center has five (5) procedure rooms at its main site in Williamsville, New York (the Maple Road Division). The Center is seeking to certify and construct an extension clinic to be located at 250 Windward Road, Suite 140, Orchard Park (Erie County), New York 14127. The extension clinic will have three (3) procedure rooms and will be named Endoscopy Center of Western New York – Orchard Park and will be identified as the Center's Southtowns Division. The extension clinic will provide gastroenterological surgical services to its patients and will be certified as a single-specialty (gastroenterology) FASC extension clinic.

Christopher J. Bartolone, M.D., an existing member of the Center and the existing Medical Director of the Center, will be the Medical Director for the Maple Road Division and the Southtowns Division. The Southtowns Division will have a Transfer and Affiliation Agreement for backup and emergency services with South Buffalo Mercy Hospital, which is located 6.1 miles and 12 minutes' travel time from the extension clinic.

### **The Ownership Transfer**

The Center currently has two (2) members, as follows: 60 Holdco, LLC (60 Holdco; 60.93%); and PE Healthcare Associates, LLC (PEHA; 39.07%). The Center is seeking approval to change the Center's ownership, as follows:

1. Transfer ownership units from PEHA to 60 Holdco;
2. Add three (3) new individual members to 60 Holdco; and
3. Create two (2) ownership divisions within the Center: the Maple Road Division and the Southtowns Division.

Overall, as a result of this project, the Center will continue to be owned by two (2) members, as follows: 60 Holdco (71.965%); and PEHA (28.035%).

This application includes a Health Equity Impact Assessment (HEIA) because it involves a change of ownership, and certain surgeons and procedures are relocating from the Center's existing main site to the proposed extension clinic. As explained in the HEIA, this project responds to and addresses a significant decline in accessible gastroenterology services in Erie County in recent years resulting from the closure of Lakeshore Medical Center, the discontinuation of gastroenterology services at Dunkirk Hospital, the closure of a competing practice and the retirement and death of several local gastroenterologists.

**New York State Department of Health  
Health Equity Impact Assessment Requirement Criteria**

Effective June 22, 2023, a Health Equity Impact Assessment (HEIA) will be required as part of Certificate of Need (CON) applications submitted by facilities (Applicant), pursuant to Public Health Law (PHL) § 2802-b and corresponding regulations at Title 10 New York Codes, Rules and Regulations (NYCRR) § 400.26. This form must be used by the Applicant to determine if a HEIA is required as part of a CON application.

**Section A. Diagnostic and Treatment Centers (D&TC) - *This section should only be completed by D&TCs, all other Applicants continue to Section B.***

**Table A.**

<b>Diagnostic and Treatment Centers for HEIA Requirement</b>	<b>Yes</b>	<b>No</b>
Is the Diagnostic and Treatment Center's patient population less than 50% patients enrolled in Medicaid and/or uninsured (combined)?	<input checked="" type="checkbox"/>	<input type="checkbox"/>
Does the Diagnostic and Treatment Center's CON application include a change in controlling person, principal stockholder, or principal member of the facility?	<input type="checkbox"/>	<input checked="" type="checkbox"/>

- ***If you checked "no" for both questions in Table A, you do not have to complete Section B - this CON application is considered exempt from the HEIA requirement. This form with the completed Section A is the only HEIA-related document the Applicant will submit with this CON application. Submit this form, with the completed Section A, along with the CON application to acknowledge that a HEIA is not required.***
- ***If you checked "yes" for either question in Table A, proceed to Section B.***

**Section B. All Article 28 Facilities**

**Table B.**

<b>Construction or equipment</b>	<b>Yes</b>	<b>No</b>
Is the project minor construction or the purchase of equipment, subject to Limited Review, <u>AND</u> will result in one or more of the following: a. Elimination of services or care, and/or; b. Reduction of 10%* or greater in the number of certified beds, certified services, or operating hours, and/or; c. Expansion or addition of 10%* or greater in the number of certified beds, certified services or operating hours? <i>Per the Limited Review Application Instructions: Pursuant to 10 NYCRR 710.1(c)(5), minor construction projects with a total project cost of less than or equal \$15,000,000 for general hospitals and less than or equal to \$6,000 for all other facilities are eligible for a Limited Review.</i>	<input type="checkbox"/>	<input checked="" type="checkbox"/>

<b>Establishment of an operator (new or change in ownership)</b>	<b>Yes</b>	<b>No</b>
Is the project an establishment of a new operator or change in ownership of an existing operator providing services or care, <u>AND</u> will result in one or more of the following: a. Elimination of services or care, and/or; b. Reduction of 10%* or greater in the number of certified beds, certified services, or operating hours, and/or; c. Change in location of services or care?	<input checked="" type="checkbox"/>	<input type="checkbox"/>
<b>Mergers, consolidations, and creation of, or changes in ownership of, an active parent entity</b>	<b>Yes</b>	<b>No</b>
Is the project a transfer of ownership in the facility that will result in one or more of the following: a. Elimination of services or care, and/or; b. Reduction of 10%* or greater in the number of certified beds, certified services, or operating hours, and/or; c. Change in location of services or care?	<input checked="" type="checkbox"/>	<input type="checkbox"/>
<b>Acquisitions</b>	<b>Yes</b>	<b>No</b>
Is the project to purchase a facility that provides a new or similar range of services or care, that will result in one or more of the following: a. Elimination of services or care, and/or; b. Reduction of 10%* or greater in the number of certified beds, certified services, or operating hours, and/or; c. Change in location of services or care?	<input type="checkbox"/>	<input checked="" type="checkbox"/>
<b>All Other Changes to the Operating Certificate</b>	<b>Yes</b>	<b>No</b>
Is the project a request to amend the operating certificate that will result in one or more of the following: a. Elimination of services or care; b. Reduction of 10%* or greater in the number of certified beds, certified services, or operating hours, and/or; c. Expansion or addition of 10%* or greater in the number of certified beds, certified services or operating hours, and/or; d. Change in location of services or care?	<input checked="" type="checkbox"/>	<input type="checkbox"/>

\*Calculate the percentage change from the number of certified/authorized beds and/or certified/authorized services (as indicated on the facility's operating certificate) specific to the category of service or care. For example, if a residential health care facility adds two ventilator-dependent beds and the facility had none previously, this would exceed the 10% threshold. If a hospital removes 5 out of 50 maternity certified/authorized beds, this would meet the 10% threshold.

- **If you checked "yes" for one or more questions in Table B**, the following HEIA documents are required to be completed and submitted along with the CON application:
  - HEIA Requirement Criteria with Section B completed
  - HEIA Conflict-of-Interest
  - HEIA Contract with Independent Entity
  - HEIA Template

- o HEIA Data Tables
  - o Full version of the CON Application with redactions, to be shared publicly
- *If you checked "no" for all questions in Table B*, this form with the completed Section B is the only HEIA-related document the Applicant will submit with this CON application. Submit this form, with the completed Section B, along with the CON application to acknowledge that a HEIA is not required.

## New York State Department of Health

### Health Equity Impact Assessment Template

Refer to the Instructions for Health Equity Impact Assessment Template for detailed instructions on each section.

#### **SECTION A. SUMMARY**

1. Title of project	Endoscopy Center of Western New York, LLC – Orchard Park
2. Name of Applicant	Endoscopy Center of WNY, LLC
3. Name of Independent Entity, including lead contact and full names of individual(s) conducting the HEIA	<p>Sachs Policy Group</p> <ul style="list-style-type: none"><li>• John Kastan (lead contact)</li><li>• Maxine Legall</li><li>• Roland Poirier</li><li>• Armaan Sodhi</li></ul>
4. Description of the Independent Entity's qualifications	<p>The Health Equity Impact Assessment (HEIA) team at Sachs Policy Group (SPG) is a diverse and experienced group dedicated to addressing health disparities and promoting equitable access to care. The team comprises experts with extensive backgrounds in health policy, provider delivery systems, population health, data analysis, community needs assessments, community engagement, and anti-racism. They are committed to understanding and improving how social, environmental, and policy factors impact health equity, particularly for historically marginalized communities.</p> <p>The team collaborates with a wide range of health care organizations, government agencies, and communities to provide strategic support with an overarching goal of advancing diversity, equity, and inclusion. Their work encompasses research and evaluation of health programs and initiatives, stakeholder engagement, policy analysis, and development of mitigation and monitoring strategies.</p> <p>In particular, the team has experience analyzing policy proposals that impact medically underserved groups, such as Medicaid programs serving low-income individuals. They are dedicated to supporting organizations that serve vulnerable populations, including safety net hospitals, community health centers, long-term care organizations, behavioral health providers, and providers that support individuals with intellectual and developmental disabilities.</p>

	The SPG HEIA team is deeply passionate about improving the health care delivery system, especially for underserved populations. The team is unwavering in its commitment to promoting equity through rigorous research, insightful yet objective consulting, and strategic advisory work
5. Date the Health Equity Impact Assessment (HEIA) started	February 13, 2024
6. Date the HEIA concluded	April 16, 2024
7. Executive summary of project (250 words max)	
<p>Through this project, SCA Health is looking to continue a partnership with the practice group Gastroenterology Associates, LLP by jointly opening a second site of service. This second site of service will serve as an extension of the partnership's existing ambulatory surgery center, Endoscopy Center of Western New York, LLC ("ECWNY") in Williamsville, NY. The new site, to be named the Endoscopy Center of Western New York, LLC with its Orchard Park, NY address ("ECWNY-OP" or the "Center"), will be in the Orchard Park, NY area south of downtown Buffalo. The need for a new ASC is primarily driven by population growth in the service area coupled with patient demand. ECWNY-OP will be exclusively providing gastrointestinal ("GI") procedures. Projections indicate that upon full transition and stabilization of the new volume, the Center is expected to perform more than 9,000 surgical GI cases annually.</p>	
8. Executive summary of HEIA findings (500 words max)	
<p>ECWNY is establishing a new ambulatory surgery center in Orchard Park, which is aimed at providing essential gastrointestinal (GI) services in the Buffalo region and the Southern Tier of New York State. The initiative responds to a significant decline in accessible GI services in recent years resulting from the closure of Lakeshore Medical Center, the discontinuation of GI services at Dunkirk Hospital, the closure of a competing GI practice in 2017, and the retirement and death of several GI physicians in the area.</p> <p>Once fully operational, the Applicant expects that the Center will conduct over 9,000 surgical GI cases annually, significantly reducing the burden on emergency rooms and hospitals. The Applicant commits to serving all individuals in need of endoscopic services without discrimination based on age, race, creed, national origin, religion, sex, sexual orientation, marital status, disability, or payment source.</p> <p>By focusing its services on the communities immediately surrounding the new location, the Applicant will actively promote awareness among local physicians and residents to address the unmet healthcare needs that initially led to its establishment. To enhance accessibility, particularly for traditionally underserved populations, the</p>	

Center will provide culturally sensitive care, offer assistance for language and physical barriers, and prioritize patient feedback for continual quality improvement.

Community stakeholders, including healthcare providers and the Erie County Department of Health, have expressed unanimous support for the project, recognizing its potential benefits to the community and healthcare system.

The underserved populations identified in the HEIA are low-income people, racial and ethnic minorities, immigrants, older adults, persons living in rural areas, people who are eligible for or receive public health benefits, and people who do not have third party health coverage or have inadequate third-party health coverage.

Moving forward, we recommend that the Applicant implement targeted outreach initiatives and foster partnerships with stakeholders in underserved communities. By prioritizing accessibility and inclusivity, the Center will increase equitable access to high-quality GI services for all residents, regardless of socio-economic status or background.

## **SECTION B: ASSESSMENT**

**For all questions in Section B, please include sources, data, and information referenced whenever possible. If the Independent Entity determines a question is not applicable to the project, write N/A and provide justification.**

### **STEP 1 – SCOPING**

1. **Demographics of service area:** Complete the “Scoping Table Sheets 1 and 2” in the document “HEIA Data Tables”. Refer to the Instructions for more guidance about what each Scoping Table Sheet requires.

Please refer to attached spreadsheet, entitled “HEIA Data Tables\_ECWNY.xlsx”.

2. **Medically underserved groups in the service area:** Please select the medically underserved groups in the service area that will be impacted by the project:

- Low-income people
- Racial and ethnic minorities
- Immigrants
- Older adults
- Persons living in rural areas
- People who are eligible for or receive public health benefits



People who do not have third-party health coverage or have inadequate third-party health coverage

3. For each medically underserved group (identified above), what source of information was used to determine the group would be impacted? What information or data was difficult to access or compile for the completion of the Health Equity Impact Assessment?

Sources of data include census data, claims data provided by the Applicant, Ambulatory Surgical Center Quality Measures data released by the federal Centers for Medicare and Medicaid Services, information obtained from the federal Uniform Data System (UDS) mapper, and qualitative data obtained from leadership interviews, stakeholder interviews, and community surveys.

For the purposes of this HEIA, the service area has been defined as Erie County, which includes the cities of Cheektowaga, Buffalo, West Seneca, Amherst, Williamsville, Buffalo, Blasdell, Lackawanna, West Seneca, Springville, Orchard Park, Lancaster, Lake View, Holland, Hamburg, Elma, Eden, East Aurora, Derby, Depew, and Angola.

4. How does the project impact the unique health needs or quality of life of each medically underserved group (identified above)?

Unless otherwise noted, the data outlined below was obtained from the US Census American Community Survey 2022.

Older Adults

The Center's service area includes, on average, individuals who are significantly older than the statewide average, with a higher median age and a higher percentage of the population 65 and over. Endoscopic services are traditionally utilized by individuals 40 years and older<sup>1</sup>.

	Median Age
Service Area	50
<b>New York State Average</b>	<b>40</b>

<sup>1</sup> <https://www.ncbi.nlm.nih.gov/pmc/articles/PMC10166951/>

Years	Service Area	NYS Average
Under 9 Years	10.4%	<b>11.1%</b>
10-19 Years	10.6%	<b>12.1%</b>
20-34 Years	17.9%	<b>20.3%</b>
35-54 Years	24.1%	<b>25.3%</b>
55-64 Years	15.7%	<b>13.6%</b>
65 and Over	21.4%	<b>17.5%</b>

### Low Income People

The Center's service area's median income is similar to the statewide average. The poverty rate is lower than the statewide average. Lower income individuals have a higher reported incidence of colorectal cancer than individuals of a higher income status<sup>2</sup>.

	Median Income	Poverty Rate
Service Area	\$77,301	5.85%
<b>New York State Average</b>	<b>\$74,314</b>	<b>10.1%</b>

### Racial and ethnic minorities

The Center's service area has racial demographics that have a higher makeup of white individuals than the statewide average. There remain significant disparities in both colorectal cancer related incidence and mortality among racial and ethnic minorities with African Americans reported to have the highest incidence and mortality<sup>3</sup>.

Race	Service Area	NYS Average
White	88.7%	<b>55.6%</b>
Black or African American	4.1%	<b>14.2%</b>
American Indian and Alaska Native	0.2%	<b>0.6%</b>
Asian	2.0%	<b>8.7%</b>
Native Hawaiian and Other Pacific Islander	0.0%	<b>0.1%</b>
Some Other Race	1.6%	<b>10.2%</b>

<sup>2</sup> <https://www.cancer.org/content/dam/cancer-org/research/cancer-facts-and-statistics/colorectal-cancer-facts-and-figures/colorectal-cancer-facts-and-figures-2020-2022.pdf>

<sup>3</sup> <https://www.ncbi.nlm.nih.gov/pmc/articles/PMC9069392/#:~:text=of%20colorectal%20cancer.,Data%20obtained%20from%20seer.cancer.gov.,Americans%20%5B4%2C10%5D.>

	% Hispanic Population
Service Area	4.0%
<b>New York State Average</b>	<b>19.5%</b>

### Immigrants

The Centers service area features significantly fewer foreign-born individuals than the statewide average. Studies have suggested that immigrants were less likely to be screened for colorectal cancer<sup>4</sup>.

	% Foreign Born Population
Service Area	4.5%
<b>New York State Average</b>	<b>22.6%</b>

### Rural Populations

The Centers service area contains a lower percentage of individuals in rural regions than the statewide average<sup>5</sup>. Studies have suggested that individuals in rural populations have a lower survival rate from colorectal cancer<sup>6</sup>.

	% Urban Population	% Rural Population
Service Area	89.0%	11.0%
<b>NYS Average</b>	<b>87.45%</b>	<b>12.55%</b>

### People who are eligible for or receive public health benefits; People who do not have third-party health coverage or have inadequate third-party health coverage

The Center's service area features fewer individuals receiving public health benefits and/or uninsured than the statewide average. Studies have suggested that individuals with colorectal cancer who were uninsured or insured by Medicaid had higher mortality rates than patients with commercial insurance<sup>7</sup>.

<sup>4</sup> <https://www.ncbi.nlm.nih.gov/pmc/articles/PMC9198177/>

<sup>5</sup> Rural is defined by the Census Bureau as all populations, housing, and territory not included within an urban area. To qualify as an urban area, the territory identified must encompass at least 2,000 housing units or have a population of at least 5,000. More information may be found on the Census Bureau [website](#).

<sup>6</sup> <https://www.ncbi.nlm.nih.gov/pmc/articles/PMC7033015/>

<sup>7</sup>

<https://www.ncbi.nlm.nih.gov/pmc/articles/PMC1446414/#:~:text=CONCLUSIONS%3A%20Patients%20with%20colorectal%20cancer,non%2DHispanic%20African%20American%20patients.>

	% Individuals with Public Health Benefits <sup>8</sup>	% of Individuals without Insurance
Service Area	39.10%	2.59%
<b>New York State Average</b>	<b>44.2%</b>	<b>5.2%</b>

5. To what extent do the medically underserved groups (identified above) currently use the service(s) or care impacted by or as a result of the project? To what extent are the medically underserved groups (identified above) expected to use the service(s) or care impacted by or as a result of the project?

Unless otherwise noted, the data outlined below was provided by the Applicant and reflects its current operations at its existing site located further north in Erie County. The new site, in Orchard Park, will create improved access to these services for individuals living in southern Erie County, as well as those living further south in Western New York State.

Older Adults:

The graph below summarizes the age of patients seen by the Applicant. The Applicant serves a higher proportion of individuals 65 and over in the data compared to the statewide average.

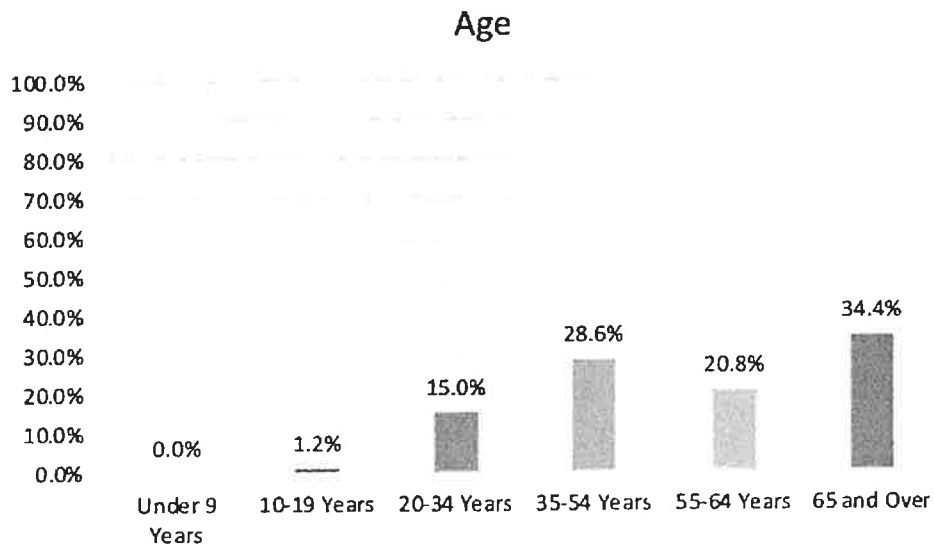

<sup>8</sup> Includes Medicare and Medicaid.

Low-income Individuals; People who are eligible for or receive public health benefits; People who do not have third-party health coverage or have inadequate third-party health coverage

The Applicant does not systematically track and report on the income of the patient populations that utilize their services, and this data is not available through public sources. The Independent Entity has used data on patients' insurance coverage as a proxy for the number of low-income people served. There was a notably higher percentage of individuals with public coverage and with no health insurance coverage reported than in the service area generally.

Health Insurance Coverage

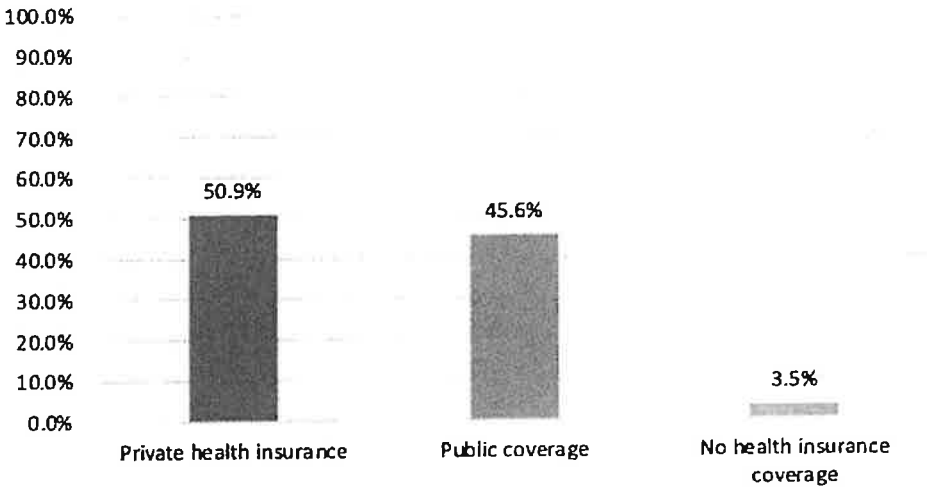

Racial and Ethnic Minorities

The graphs below summarize the ethnic and racial demographics of the patient population served by the Applicant. The Applicant currently sees a lower proportion of White patients than is representative of the service area. Similarly, the number of Hispanic individuals seen is higher than is representative of the service area.

### Race

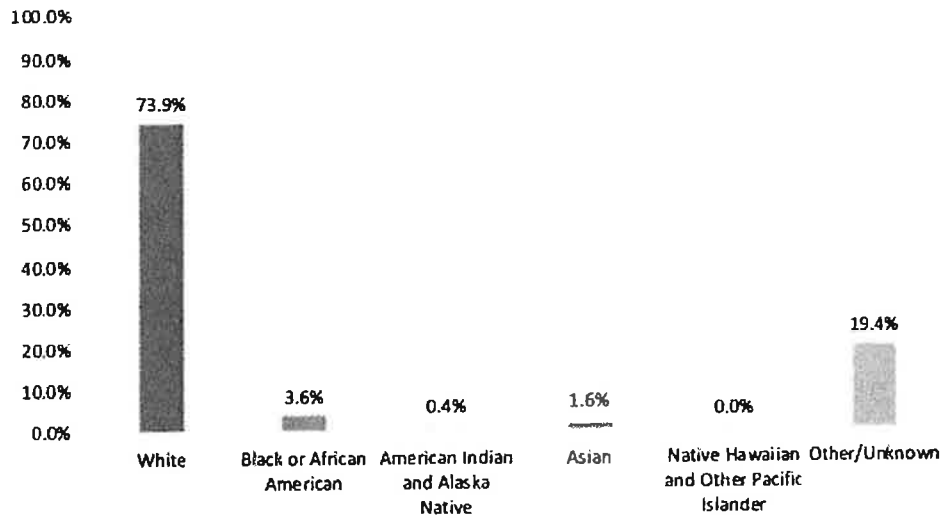

### Ethnicity

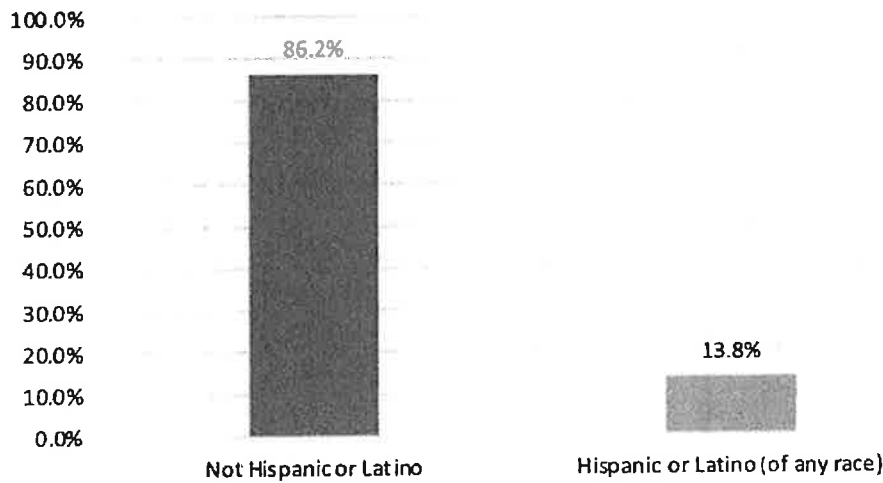

### Immigrants

The Applicant does not systematically track and report on the immigrant status of the other patient populations that utilize their services, and this data is not available through public sources.

### Rural Populations

The graph below summarizes the patient population by rural and urban status. The applicant serves a higher proportion of individuals from rural regions in the data compared to the statewide average.

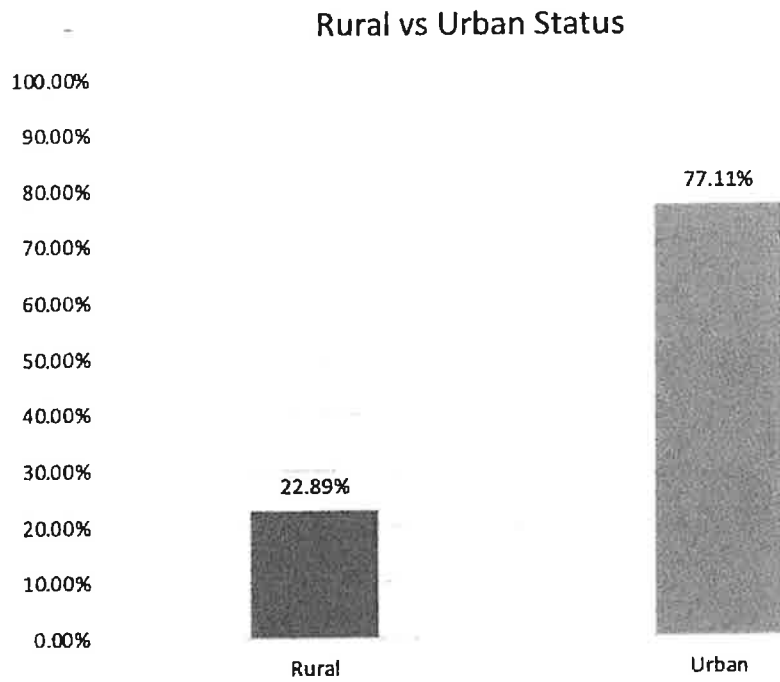

For all medically underserved groups identified above who reside in southern Erie County and areas further south, this Project should increase their access to GI services. Stakeholder interviews, both with the Applicant and local referral sources, indicated that there exists a need for additional endoscopic services.

Access has been particularly constrained by the closure of Lakeshore Healthcare Center in 2020 and Dunkirk Memorial Hospital’s discontinuation of GI services in 2023<sup>9</sup>. This new Center will increase the availability of GI services, providing greater access to such services for the greater community and its medically underserved individuals.

**6. What is the availability of similar services or care at other facilities in or near the Applicant's service area?**

Facility	Distance From New Center <sup>10</sup>
<b>Endoscopy Center of Western New York, LLC</b>	0.3 Miles
<b>Premier Ambulatory Surgery Center</b>	7 Miles
<b>Buffalo Surgery Center</b>	15 Miles

<sup>9</sup> <https://www.wkbw.com/news/local-news/southern-tier/theres-just-no-excuse-healthcare-workers-rallying-for-ny-state-to-release-brooks-hospital-funds>

<sup>10</sup> These distances were calculated through google maps

**Sterling Surgical Center**  
**Center for Ambulatory Surgery LLC**  
**Ambulatory Surgery Center of WNY**

2 Miles  
5 Miles  
15 Miles

7. What are the historical and projected market shares of providers offering similar services or care in the Applicant’s service area?

Based on CMS’s 2022 Ambulatory Surgical Center Quality Measures data, the chart below represents the market share by number of discharges.

Facility	% of Discharges
Endoscopy Center of Western New York, LLC	27.8%
Premier Ambulatory Surgery Center	2.1%
Buffalo Surgery Center	34.8%
Sterling Surgical Center LLC	10.5%
Center for Ambulatory Surgery LLC	17.6%
Ambulatory Surgery Center of WNY	7.3%

8. Summarize the performance of the Applicant in meeting its obligations, if any, under Public Health Law § 2807-k (General Hospital Indigent Care Pool) and federal regulations requiring the provision of uncompensated care, community services, and/or access by minorities and people with disabilities to programs receiving federal financial assistance. Will these obligations be affected by implementation of the project? If yes, please describe.

N/A

9. Are there any physician and professional staffing issues related to the project or any anticipated staffing issues that might result from implementation of project? If yes, please describe.

All staff at the proposed Center will be newly hired. Planned staffing includes a director of nursing (1), registered nurses (9), front desk workers (3), endoscopy technicians (5), and a unit assistant (1).

Despite the challenge to recruit and retain staff in this area of upstate New York, the Applicant has expressed confidence in its ability to recruit and retain a strong complement of professionals.

10. Are there any civil rights access complaints against the Applicant? If yes, please describe.



No

11. Has the Applicant undertaken similar projects/work in the last five years? If yes, describe the outcomes and how medically underserved group(s) were impacted as a result of the project. Explain why the applicant requires another investment in a similar project after recent investments in the past.

No

## STEP 2 – POTENTIAL IMPACTS

1. For each medically underserved group identified in Step 1 Question 2, describe how the project will:
  - a. Improve access to services and health care
  - b. Improve health equity
  - c. Reduce health disparities

The applicant provides colonoscopies, a procedure that can prevent colon cancer and other GI diseases. This reduces the burden of disease on the historically underserved thereby reducing health disparities.

- **Low-Income People:** Low-income populations often face significant barriers to accessing specialized healthcare services due to cost and availability<sup>11</sup>. Individuals with lower socio-economic status also have a higher incidence of colorectal cancer<sup>12</sup>. An endoscopy center that offers affordable services can directly enhance access to crucial diagnostic and preventive care, reducing the long-term costs associated with late-stage disease treatment by detecting these diseases early. This group benefits from improved affordability and accessibility, addressing key elements of health equity<sup>13</sup>.
- **Racial and Ethnic Minorities:** Historical disparities in healthcare have disproportionately affected racial and ethnic minorities, leading to worse health outcomes in these groups. There are significant disparities in both colorectal cancer related incidence and mortality among racial and ethnic minorities with African Americans reported to have the highest incidence

---

<sup>11</sup> <https://www.wolterskluwer.com/en/expert-insights/five-key-barriers-to-healthcare-access-in-the-united-states>  
<sup>12</sup>

<https://www.ncbi.nlm.nih.gov/pmc/articles/PMC3422782/#:~:text=The%20overall%20incidence%20of%20CRC,accounting%20for%20other%20risk%20factors.>

<sup>13</sup>

[https://www.aha.org/system/files/media/file/2021/03/Market\\_Insights\\_Disparities\\_Data.pdf#:~:text=URL%3A%20https%3A%2F%2Fwww.aha.org%2Fsystem%2Ffiles%2Fmedia%2Ffile%2F2021%2F03%2FMarket\\_Insights\\_Disparities\\_Data.pdf%0AVisible%3A%200%25%20](https://www.aha.org/system/files/media/file/2021/03/Market_Insights_Disparities_Data.pdf#:~:text=URL%3A%20https%3A%2F%2Fwww.aha.org%2Fsystem%2Ffiles%2Fmedia%2Ffile%2F2021%2F03%2FMarket_Insights_Disparities_Data.pdf%0AVisible%3A%200%25%20)

and mortality rates<sup>14</sup>. By providing culturally competent care and ensuring that services are accessible and respectful of cultural needs, an endoscopy center can help bridge these gaps. Such centers can also focus on community outreach and education, which are essential for increasing awareness about the importance of early disease detection and preventive care<sup>15</sup>.

- **Immigrants:** Immigrants may face language barriers, lack of familiarity with the healthcare system, and fear of accessing services due to immigration status concerns. This has resulted in immigrant status being associated with lower likelihood of colorectal cancer screening<sup>16</sup>. An endoscopy center that offers multilingual services and operates under policies that protect all patients can significantly improve these individuals' ability to seek and receive care.
- **Older Adults:** Endoscopic services are traditionally utilized by individuals 40 years and older<sup>17</sup>. Older adults are at a higher risk for conditions like colorectal cancer, which makes access to endoscopy services crucial. The proximity of services can reduce the need for long-distance travel, which can be challenging for this group. Additionally, age-appropriate care and communication can improve their ability to engage with healthcare providers and follow through with recommended treatments.
- **Persons Living in Rural Areas:** Residents of rural areas often have limited access to specialized healthcare services. A new endoscopy center in or near these areas can dramatically reduce the travel time and inconvenience associated with obtaining necessary care, thus improving the availability and accommodation of services. This also helps in early detection and treatment of diseases, which can be lifesaving<sup>18</sup>.
- **People Who Are Eligible For or Receive Public Health Benefits:** Studies have indicated that individuals with Medicaid had higher mortality rates from colorectal cancer compared to patients with commercial insurance<sup>19</sup>. Medicaid recipients are often from lower socioeconomic background. These groups have higher rates of certain health conditions (including colorectal cancer) due to factors such as limited access to healthy food, higher rates of smoking, and less access to preventive care. Medicaid patients may experience delays in screening and diagnosis due

---

<sup>14</sup> <https://www.ncbi.nlm.nih.gov/pmc/articles/PMC9069392/#:~:text=of%20colorectal%20cancer.-,Data%20obtained%20from%20seer.cancer.gov.,Americans%20%5B4%2C10%5D>.

<sup>15</sup> [https://www.cdc.gov/pcd/issues/2021/21\\_0264.htm](https://www.cdc.gov/pcd/issues/2021/21_0264.htm)

<sup>16</sup> <https://www.ncbi.nlm.nih.gov/pmc/articles/PMC9198177/>

<sup>17</sup> <https://www.ncbi.nlm.nih.gov/pmc/articles/PMC10166951/>

<sup>18</sup> <https://equityhealthj.biomedcentral.com/articles/10.1186/s12939-016-0351-7>

<sup>19</sup>

<https://www.ncbi.nlm.nih.gov/pmc/articles/PMC1446414/#:~:text=CONCLUSIONS%3A%20Patients%20with%20colorectal%20cancer,non%2DHispanic%20African%20American%20patients>.

to various barriers such as fewer healthcare providers accepting Medicaid, longer wait times for appointments, and lower access to specialty care. Early detection of colorectal cancer through routine screenings like colonoscopies significantly reduces mortality, but delays in screening can lead to diagnosis at later, more dangerous stages of the disease.

- **People Who Do Not Have Third-Party Health Benefits Or Have Inadequate Third-Party Health Coverage:** For individuals without health insurance, cost is a significant barrier to accessing healthcare services. Studies have suggested that individuals with colorectal cancer who were uninsured had higher mortality rates than patients with commercial insurance<sup>20</sup>. An endoscopy center providing services at a reduced cost or on a sliding scale can make life-saving diagnostic and preventive care accessible to uninsured populations. This directly addresses affordability and helps in reducing health disparities by ensuring that financial constraints do not prevent individuals from receiving early and appropriate care.

2. For each medically underserved group identified in Step 1 Question 2, describe any unintended positive and/or negative impacts to health equity that might occur as a result of the project.

The intended benefit of this project, described above, is to increase access to GI services.

By providing specialized medical services such as endoscopy closer to rural communities, residents perceive a genuine commitment to their health needs. Consistent and reliable care helps build trust over time. This direct investment in local healthcare infrastructure demonstrates that their well-being is a priority, which can build trust between healthcare providers and the community. Additionally, building trust in healthcare communities is essential for ensuring patients feel comfortable seeking care, adhering to treatment plans, and engaging with healthcare providers.

3. How will the amount of indigent care, both free and below cost, change (if at all) if the project is implemented? Include the current amount of indigent care, both free and below cost, provided by the Applicant.

---

20

<https://www.ncbi.nlm.nih.gov/pmc/articles/PMC1446414/#:~:text=CONCLUSIONS%3A%20Patients%20with%20colorectal%20cancer,non%2DHispanic%20African%20American%20patients.>

It is anticipated that the proportion of indigent care at the new site in southern Erie County will be similar to the proportion of indigent care provided at the existing site.

Indigent Care Funding (Individuals they are not Billing)	Year	Proportion of Individuals Served	Indigent Care Funding
<b>Bad Debt</b>	<b>2023</b>	81%	\$10,927.14
<b>Bankrupt</b>	<b>2023</b>	1%	\$4,302.72
<b>Courtesy Discount</b>	<b>2023</b>	6%	\$3,280.42
<b>Uncompensated Care</b>	<b>2023</b>	12%	\$3,194.00

4. Describe the access by public or private transportation, including Applicant-sponsored transportation services, to the Applicant's service(s) or care if the project is implemented.

Patients need a responsible driver when traveling to and from the Center due to the pre-procedure preparation and the post-procedure effects of the anesthesia. There is a lack of accessible public transportation (such as bus routes); however, during internal interviews, the Applicant and stakeholders shared that most individuals in the community served have cars. The Center will work with patients who lack a responsible driver to obtain transportation through local providers. Medicaid patients have access to Ambulette services to provide safe transportation for their scheduled procedure. Patients can also take a ride share service, like Uber, when they have a responsible person with them to and from the Center.

5. Describe the extent to which implementation of the project will reduce architectural barriers for people with mobility impairments.

The Center will be compliant with the Americans with Disabilities Act.

#### Meaningful Engagement

1. List the local health department(s) located within the service area that will be impacted by the project.

Erie County Department of Health

2. Did the local health department(s) provide information for, or partner with, the Independent Entity for the HEIA of this project?

Yes, the local health department provided information for this project. Additionally, the local health department refers patients to the Applicant for services.

3. **Meaningful engagement of stakeholders: Complete the “Meaningful Engagement” table in the document titled “HEIA Data Table”. Refer to the Instructions for more guidance.**

Please refer to the completed excel file titled “HEIA Data Tables\_ECWNY.xlsx”.

Interviews with Key Stakeholders for the Center proposal was conducted through seven 30-to-60-minute interviews over zoom or telephone.

4. **Based on your findings and expertise, which stakeholders are most affected by the project? Has any group(s) representing these stakeholders expressed concern the project or offered relevant input?**

Aside from individuals needing GI services, the stakeholders primarily affected are primary care providers (or other healthcare entities) seeking to refer their patients for GI services. The Independent Entity interviewed four of these stakeholders. The Erie County Department of Health provides primary care to many of the county's uninsured patients and regularly refers such patients to the Applicant for GI services. The David Kowalski Family Practice and the East Aurora Family Practice are primary care practices that are key referrals sources for the Applicant. In addition, Arab American Community Center for Economic and Social Services (ACCESS) of Western New York was very supportive of the new center. All four stakeholders strongly supported this Project and the increased GI access it would provide.

5. **How has the Independent Entity’s engagement of community members informed the Health Equity Impact Assessment about who will benefit as well as who will be burdened from the project?**

The stakeholder engagement confirmed two key aspects of the HEIA. First, each conversation supported the Applicant’s assessment that the region had a need for greater access to GI services. Second, the conversations confirmed that the Applicant has a good reputation for providing GI services to medically underserved populations. By way of example, the Erie County Department of Health affirmed that it values its partnership with the Applicant in ensuring access to care to local uninsured patients. The two interviewed physician practices concurred with this. Throughout the interviews, none of the stakeholders identified a medically underserved group that would be negatively impacted by the Project.

6. **Did any relevant stakeholders, especially those considered medically underserved, not participate in the meaningful engagement portion of the Health Equity Impact Assessment? If so, list.**

No.

### **DSTEP 3 – MITIGATION**

1. If the project is implemented, how does the Applicant plan to foster effective communication about the resulting impact(s) to service or care availability to the following:
  - a. People of limited English-speaking ability
  - b. People with speech, hearing or visual impairments
  - c. If the Applicant does not have plans to foster effective communication, what does the Independent Entity advise?

The Applicant has language supports for non-English speaking patients. For non-English speaking patients, the Applicant posts information regarding the availability of free language assistance services in multiple languages. Pacific Interpreters Language Line is the vendor.

For the visually impaired, the Applicant provides wayfinding that is ADA compliant. Policies and procedures are in place which allow for a service animal and for advocates to be present and assist the patient.

For the hearing impaired, the Applicant utilizes a language service that offers American Sign Language (ASL) services.

2. **What specific changes are suggested so the project better meets the needs of each medically underserved group (identified above)?**

To better meet the needs of each medically underserved group, the Applicant should implement a series of proactive and continuous communication channels with the community. Additionally, offering educational workshops or seminars on overall colon health and cancer prevention. The dialogue channels should allow for regular feedback and discussions about health needs and services. Each communication strategy should be crafted to fit individual medically underserved groups.

3. **How can the Applicant engage and consult impacted stakeholders on forthcoming changes to the project?**

To further enhance the engagement and consultation process with impacted stakeholders on forthcoming changes to the project, the Applicant can adopt a more structured and proactive approach to communicating updates (such as staffing changes or changes in hours) occurring at the Center once operational.

4. **How does the project address systemic barriers to equitable access to services or care? If it does not, how can the project be modified?**

The Project has begun addressing systemic barriers to equitable access by generally increasing access to specialty care in a geographic area where such

access is limited. In addition, the Applicant has a prior history and commitment of providing such care to medically underserved communities. The ongoing outreach and engagement with these groups during the Project's construction and go-live process could further address such barriers by maximizing the number of such people accessing services at the Center.

#### **STEP 4 – MONITORING**

- 1. What are existing mechanisms and measures the Applicant already has in place that can be leveraged to monitor the potential impacts of the project?**

The Applicant has robust systems in place to monitor potential impacts of the project. The Applicant employs the Gastroenterology Quality Improvement Consortium (GIQuIC), which provides continuous enhancement of provider performance. This system tracks and analyzes various quality metrics (such as patient wait times, patient safety and quality control, documentation and compliance, and clinical management and treatment protocols), offering a dynamic platform for assessing the effectiveness of new practices or procedures introduced by the project.

Stakeholder interviews indicated that the applicant consistently achieves favorable outcomes on Press Ganey surveys, a tool that gathers and evaluates patient feedback. These scores reflect high patient satisfaction and can serve as a crucial indicator of the project's impact on patient experience and engagement.

Together, these tools provide a comprehensive framework for monitoring both the clinical and patient-centered outcomes of the project, ensuring any shifts in performance are promptly identified and addressed. Both tools involve health equity measures as they track patients' demographic information.

- 2. What new mechanisms or measures can be created or put in place by the Applicant to ensure that the Applicant addresses the findings of the HEIA?**

To ensure that the Applicant effectively addresses the findings of this HEIA, several new mechanisms and measures can be established. The Applicant can design and implement targeted programs that are specifically tailored to meet the unique needs of underserved populations.

Increasing outreach efforts is crucial. The Applicant should initiate comprehensive outreach campaigns aimed at engaging underserved communities more actively, thereby fostering greater accessibility to healthcare services. These campaigns should include partnerships with local organizations.

The Applicant can establish a feedback loop with these communities to continually assess the effectiveness of the outreach and adapt strategies as necessary. This approach ensures that the services provided are relevant and responsive to these communities' needs and builds trust and encourages community participation in health programs.

## **STEP 5 – DISSEMINATION**

The Applicant is required to publicly post the CON application and the HEIA on its website within one week of acknowledgement by the Department. The Department will also publicly post the CON application and the HEIA through NYSE-CON within one week of the filing.

**OPTIONAL: Is there anything else you would like to add about the health equity impact of this project that is not found in the above answers? (250 words max)**

This center can significantly impact health equity within the community by making concerted efforts to identify and communicate more intentionally with underserved populations. Enhancing engagement with these groups can ensure that the services provided are accessible and tailored to meet their specific needs, thus improving overall health outcomes, and reducing disparities.



----- SECTION BELOW TO BE COMPLETED BY THE APPLICANT -----

**SECTION C. ACKNOWLEDGEMENT AND MITIGATION PLAN**

*Acknowledgment by the Applicant that the Health Equity Impact Assessment was reviewed by the facility leadership before submission to the Department. This section is to be completed by the Applicant, not the Independent Entity.*

**I. Acknowledgement**

I, (APPLICANT), attest that I have reviewed the Health Equity Impact Assessment for the (PROJECT TITLE) that has been prepared by the Independent Entity, (NAME OF INDEPENDENT ENTITY).

Christopher J. Bartolone, M.D.

Name

Medical Director

Title



Signature

12/23/24

Date

**II. Mitigation Plan**

If the project is approved, how has or will the Applicant mitigate any potential negative impacts to medically underserved groups identified in the Health Equity Impact Assessment? (1000 words max)

*Please note: this narrative must be made available to the public and posted conspicuously on the Applicant's website until a decision on the application has been made.*

New York State Department of Health

Health Equity Impact Assessment Template

## II. Mitigation Plan

If the **Endoscopy Center of Western New York, LLC (ECWNY)** receives approval to extend their Certificate of Need (CON) to an additional location (250 Windward Road, Suite 140, Orchard Park, NY 14127) ECWNY will use this location to communicate more intentionally with underserved populations.

Gastroenterology Associates, LLP, the medical practice associated with the physicians that perform procedures at ECWNY, are currently in talks with Catholic Health on a Health Equity project to perform screening colonoscopies on a back log of their Medicare patients. The patients in question reside in various communities surrounding both the current ECWNY location and the proposed location. Both centers would be used to service the patients in question and if the project is successful, Catholic Health may be interested in the centers servicing other patient groups that may not be receiving or have appropriate access to gastroenterology specialty services.

In addition, ECWNY believes that if the additional location is approved, it could be of service to existing patients of Neighborhood Health Center located in Blasdell, NY. Neighborhood Health Center is an inclusive and welcoming healthcare organization (non-for-profit) that services individuals regardless of insurance status or ability to pay. This center is located 3.7 miles away from ECWNY's proposed location.

In addition, the proposed location is between Route 90 and Route 219 which provide easy access from both underserved urban areas such as Lackawanna and underserved rural areas to the south (Southern Tier) extending into Northern Pennsylvania. This underserved rural area is home to the Seneca Nation of Indians (Cattaraugus, Allegany and Oil Springs Reservations).

The current ECWNY location has serviced patients from Neighborhood Health Center, individuals from Lackawanna, the Southern Tier, and the Seneca Nation of Indians. We expect these patient populations to increase based on the proximity to the new office.

Furthermore, through the HEIA process, a physician owner of ECWNY (who is a Muslim leader in an Amherst NY Mosque) reached out to cultural leaders in the City of Lackawanna and made a connection with Access of WNY, a non-for-profit community organization representing approximately six-thousand Yemeni and other Arab immigrants. It was determined that Access of WNY has a need and ability to educate their members with respect to colon cancer and the importance of cancer screening and treatment of other gastrointestinal issues.

ECWNY plans on establishing relationships and programs to service these underserved populations.

**New York State Department of Health  
Certificate of Need Application**

**Schedule 1**

**Acknowledgement and Attestation**

I hereby certify, under penalty of perjury, that I am duly authorized to subscribe and submit this application on behalf of the applicant: Endoscopy Center of Western New York, LLC

I further certify that the information contained in this application and its accompanying schedules and attachments are accurate, true and complete in all material respects. I acknowledge and agree that this application will be processed in accordance with the provisions of articles 28, 36 and 40 of the public health law and implementing regulations, as applicable.

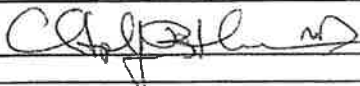
SIGNATURE:	DATE
	12/23/2024
PRINT OR TYPE NAME	TITLE
Christopher J. Bartolone, M.D.	Member and Medical Director

**General Information**

		Title of Attachment:
Is the applicant an existing facility? If yes, attach a photocopy of the resolution or consent of partners, corporate directors, or LLC managers authorizing the project.	YES <input type="checkbox"/> NO <input checked="" type="checkbox"/>	Schedule 1 Att.
Is the applicant part of an "established PHL Article 28* network" as defined in section 401.1(j) of 10 NYCRR? If yes, attach a statement that identifies the network and describes the applicant's affiliation. Attach an organizational chart.	YES <input type="checkbox"/> NO <input checked="" type="checkbox"/>	

**Contacts**

The Primary and Alternate contacts are the only two contacts who will receive email notifications of correspondence in NYSE-CON. **At least one of these two contacts should be a member of the applicant.** The other may be the applicant's representative (e.g., consultant, attorney, etc.). What is entered here for the Primary and Alternate contacts should be the same as what is entered onto the General Tab in NYSE-CON.

Primary Contact	NAME AND TITLE OF CONTACT PERSON	CONTACT PERSON'S COMPANY	
	Frank M. Cicero	Cicero Consulting Associates	
	BUSINESS STREET ADDRESS		
	925 Westchester Avenue, Suite 201		
	CITY	STATE	ZIP
	White Plains	New York	10604
	TELEPHONE	E-MAIL ADDRESS	
(914) 682-8657	conadmin@ciceroassociates.com		

Alternate Contact	NAME AND TITLE OF CONTACT PERSON	CONTACT PERSON'S COMPANY	
	Ann Sariego	PE Healthcare Associates, LLC	
	BUSINESS STREET ADDRESS		
	2500 York Road, Suite 300		
	CITY	STATE	ZIP
	Jamison	PA	18929
	TELEPHONE	E-MAIL ADDRESS	
(917) 509-6978	annie.sariego@scasurgery.com		

**New York State Department of Health  
Certificate of Need Application**

**Schedule 1**

The applicant must identify the operator's chief executive officer, or equivalent official.

<b>CHIEF EXECUTIVE</b>	NAME AND TITLE		
	Christopher J. Bartolone, M.D., Manager		
	BUSINESS STREET ADDRESS		
	60 Maple Road		
	CITY	STATE	ZIP
	Williamsville	New York	14221
	TELEPHONE	E-MAIL ADDRESS	
(877) 442-3687	cbartolone@gastrowny.com		

The applicant's lead attorney should be identified:

<b>ATTORNEY</b>	NAME		FIRM	BUSINESS STREET ADDRESS
	Amber McGraw Walsh, Esq.		McGuireWoods LLP	77 West Wacker Drive, Suite 4100
	CITY, STATE, ZIP		TELEPHONE	E-MAIL ADDRESS
	Chicago, IL 60601		(312) 750-3596	AWalsh@mcguirewoods.com

If a consultant prepared the application, the consultant should be identified:

<b>CONSULTANT</b>	NAME		FIRM	BUSINESS STREET ADDRESS
	Frank M. Cicero		Cicero Consulting Associates	925 Westchester Avenue, Suite 201
	CITY, STATE, ZIP		TELEPHONE	E-MAIL ADDRESS
	White Plains, New York 10604		(914) 682-8657	conadmin@ciceroassociates.com

The applicant's lead accountant should be identified: **Please contact consultant**

<b>ACCOUNTANT</b>	NAME		FIRM	BUSINESS STREET ADDRESS
	CITY, STATE, ZIP		TELEPHONE	E-MAIL ADDRESS

Please list all Architects and Engineer contacts:

<b>ARCHITECT and/or ENGINEER</b>	NAME		FIRM	BUSINESS STREET ADDRESS
	Philip J. Silvestri		Silvestri Architects, PC	1321 Millersport Hwy, Suite 101
	CITY, STATE, ZIP		TELEPHONE	E-MAIL ADDRESS
Buffalo, New York 14221		(716) 525-8180	philips@silvestriarchitects.com	

<b>ARCHITECT and/or ENGINEER</b>	NAME		FIRM	BUSINESS STREET ADDRESS
	CITY, STATE, ZIP		TELEPHONE	E-MAIL ADDRESS

**New York State Department of Health  
Certificate of Need Application**

**Schedule 1**

**Other Facilities Owned or Controlled by the Applicant**

*Establishment (with or without Construction) Applications only*

**NYS Affiliated Facilities/Agencies**

Does the applicant legal entity or any related entity (parent, member or subsidiary corporation) operate or control any of the following in New York State? **SCHEDULE 1 ATTACHMENT**

FACILITY TYPE - NEW YORK STATE	FACILITY TYPE	
Hospital	HOSP	Yes <input type="checkbox"/> No <input checked="" type="checkbox"/>
Nursing Home	NH	Yes <input type="checkbox"/> No <input checked="" type="checkbox"/>
Diagnostic and Treatment Center	DTC	Yes <input checked="" type="checkbox"/> No <input type="checkbox"/>
Midwifery Birth Center	MBC	Yes <input type="checkbox"/> No <input checked="" type="checkbox"/>
Licensed Home Care Services Agency	LHCSA	Yes <input type="checkbox"/> No <input checked="" type="checkbox"/>
Certified Home Health Agency	CHHA	Yes <input type="checkbox"/> No <input checked="" type="checkbox"/>
Hospice	HSP	Yes <input type="checkbox"/> No <input checked="" type="checkbox"/>
Adult Home	ADH	Yes <input type="checkbox"/> No <input checked="" type="checkbox"/>
Assisted Living Program	ALP	Yes <input type="checkbox"/> No <input checked="" type="checkbox"/>
Long Term Home Health Care Program	LTHHCP	Yes <input type="checkbox"/> No <input checked="" type="checkbox"/>
Enriched Housing Program	EHP	Yes <input type="checkbox"/> No <input checked="" type="checkbox"/>
Health Maintenance Organization	HMO	Yes <input type="checkbox"/> No <input checked="" type="checkbox"/>
Other Health Care Entity	OTH	Yes <input type="checkbox"/> No <input checked="" type="checkbox"/>

Upload as an attachment to Schedule 1, the list of facilities/agencies referenced above, in the format depicted below:

Facility Type	Facility Name	Operating Certificate or License Number	Facility ID (PFI)
---------------	---------------	---	-------------------

**Out-of-State Affiliated Facilities/Agencies** **N/A**

In addition to in-state facilities, please upload, as an attachment to Schedule 1, a list of all health care, adult care, behavioral, or mental health facilities, programs or agencies located outside New York State that are affiliated with the applicant legal entity, as well as with parent, member and subsidiary corporations, in the format depicted below.

Facility Type	Name	Address	State/Country	Services Provided
---------------	------	---------	---------------	-------------------

In conjunction with this list, you will need to provide documentation from the regulatory agency in the state(s) where affiliations are noted, reflecting that the facilities/programs/agencies have operated in substantial compliance with applicable codes, rules and regulations for the past ten (10) years (or for the period of the affiliation, whichever is shorter). More information regarding this requirement can be found in Schedule 2D.

**ENDOSCOPY CENTER OF WESTERN NEW YORK, LLC**

**SCHEDULE 1 ATTACHMENTS**

1. **Project Narrative**
2. **Affiliated Facilities – PE Healthcare Associates, LLC**
3. **Curriculum Vitae – Medical Director**
4. **Hospital Transfer Agreement**
5. **Physician Letters of Interest**
6. **Member Resolution**



December 20, 2024

The Endoscopy Center of Western New York, LLC  
60 Maple Road, Suite 2  
Williamsville, NY 14221

Dr. Bartolone,

Based on conversations between our organizations, Catholic Health understands Endoscopy Center of Western New York, LLC has plans to extend its Certificate of Need to a location in Orchard Park New York and will be seeking Certificate of Need Approval to certify and construct The Endoscopy Center of Western New York – Orchard Park, an Article 28 extension clinic of your existing Freestanding Ambulatory Surgical Center in Erie County.

Catholic Health's Buffalo Mercy Hospital (BMH) would be interested in entering into a transfer and affiliation agreement with your center to serve as its backup hospital for emergency services, and would discuss providing other services such as laboratory, radiology and any other services that you may need (e.g., social work services, quality oversight and utilization review), at rates to be determined based on negotiation.

We look forward to further conversations relating to these collaborative opportunities to serve the respective communities. Please contact leadership at BMH when you have received establishment approval to begin discussions regarding the potential opportunities.

Sincerely,

A handwritten signature in black ink that reads "James M. Garvey".

James M. Garvey  
Executive Vice President; Chief Operating Officer

**MEMBER RESOLUTION**

**ENDOSCOPY CENTER OF WESTERN NEW YORK, LLC**

The undersigned being a member of Endoscopy Center of Western New York, LLC, an existing free standing ambulatory surgery center, does hereby ratify and confirm, approve and adopt the following as and for the resolutions of Endoscopy Center of Western New York, LLC:

**WHEREAS**, Endoscopy Center of Western New York, LLC desires to certify and construct an extension clinic under Article 28 of the New York Public Health Law; and

**WHEREAS**, in order to accomplish the foregoing, Endoscopy Center of Western New York, LLC must file with the New York State Department of Health a Full Review Certificate of Need Application (**CON Application**).

**NOW, THEREFORE**, be it

**RESOLVED**, that Endoscopy Center of Western New York, LLC is hereby authorized, directed and empowered to submit a CON Application to the New York State Department of Health, for the purpose of certifying and constructing an extension clinic, under Article 28 of the New York Public Health Law; and it is further

**RESOLVED**, that Endoscopy Center of Western New York, LLC is authorized to perform any and all acts, which may be required in order to accomplish the foregoing.

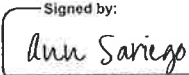
By:  Signed by:  
Ann Sariego  
Member, PE Healthcare Associates, LLC  
Endoscopy Center of Western New York, LLC



# Schedule 6 Architectural/Engineering Submission

## Contents:

- Schedule 6 – Architectural/Engineering Submission

**Architectural Submission Requirements for Contingent Approval and Contingency Satisfaction**

Schedule applies to all projects with construction, including Articles 28 & 40, i.e., Hospitals, Diagnostic and Treatment Centers, Residential Health Care Facilities, and Hospices.

**Instructions**

- Provide Architectural/Engineering Narrative using the format below.
- Provide Architect/Engineer Certification form:
  - [Architect's Letter of Certification for Proposed Construction or Renovation for Projects That Will Be Self-Certified. Self-Certification Is Not an Option for Projects over \\$15 Million, or Projects Requiring a Waiver](#) (PDF)
  - [Architect's Letter of Certification for Proposed Construction or Renovation Projects to Be Reviewed by DOH or DASNY](#). (PDF) (Not to Be Submitted with Self-Certification Projects)
  - [Architect's Letter of Certification for Completed Projects](#) (PDF)
  - [Architect's or Engineer's Letter of Certification for Inspecting Existing Buildings](#) (PDF)
- Provide FEMA BFE Certificate. Applies only to Hospitals and Nursing Homes.
  - [FEMA Elevation Certificate and Instructions.pdf](#)
- Provide Functional Space Program: A list that enumerates project spaces by floor indicating size by gross floor area and clear floor area for the patient and resident spaces.
- For projects with imaging services, provide Physicist's Letter of Certification and Physicist's Report including drawings, details and supporting information at the design development phase.
  - [Physicist's Letter of Certification](#) (PDF)
- Provide Architecture/Engineering Drawings in PDF format created from the original electronic files; scans from printed drawings will not be accepted. Drawing files less than 100 MB, and of the same trade, may be uploaded as one file.
  - [NYSDOH and DASNY Electronic Drawing Submission Guidance for CON Reviews](#)
  - [DSG-1.0 Schematic Design & Design Development Submission Requirements](#)
- Refer to the Required Attachment Table below for the Schematic Design Submission requirements for Contingent Approval and the Design Development Submission requirements for Contingency Satisfaction.
  - Attachments must be labeled accordingly when uploading in NYSE-CON.
  - Do not combine the Narrative, Architectural/Engineering Certification form and FEMA BFE Certificate into one document.
  - If submitted documents require revisions, provide an updated Schedule 6 with the revised information and date within the narrative.

**Architecture/Engineering Narrative**

Narrative shall include but not limited to the following information. Please address all items in the narrative including items located in the response column. Incomplete responses will not be accepted.

<b>Project Description</b>	
Schedule 6 submission date: 6/20/2024	Revised Schedule 6 submission date: Click to enter a date.
Does this project amend or supersede prior CON approvals or a pending application? No If so, what is the original CON number? N/A	
Intent/Purpose: Construct an extension clinic - Ambulatory Surgical Center for gastroenterology procedures.	
Site Location: Windward Rd (SBL 152.18-2-6), Orchard Park, New York 14127	
Brief description of current facility, including facility type:	

# New York State Department of Health Certificate of Need Application

## Schedule 6

N/A	
Brief description of proposed facility: New construction 1 story medical office building.	
Location of proposed project space(s) within the building. Note occupancy type for each occupied space. Northwest corner of multi-tenant	
Indicate if mixed occupancies, multiple occupancies and or separated occupancies. Describe the required smoke and fire separations between occupancies: All B occupancies, 1 hr separation from surgery center	
If this is an existing facility, is it currently a licensed Article 28 facility?	Not Applicable
Is the project space being converted from a non-Article 28 space to an Article 28 space?	No
Relationship of spaces conforming with Article 28 space and non-Article 28 space: 1 hr separation from other tenants that may or may not be Article 28	
List exceptions to the NYSDOH referenced standards. If requesting an exception, note each on the Architecture/Engineering Certification form under item #3. N/A	
Does the project involve heating, ventilating, air conditioning, plumbing, electrical, water supply, and fire protection systems that involve modification or alteration of clinical space, services or equipment such as operating rooms, treatment, procedure rooms, and intensive care, cardiac care , other special care units (such as airborne infection isolation rooms and protective environment rooms), laboratories and special procedure rooms, patient or resident rooms and or other spaces used by residents of residential health care facilities on a daily basis? If so, please describe below. N/A	Not Applicable
Provide brief description of the existing building systems within the proposed space and overall building systems, including HVAC systems, electrical, plumbing, etc. New construction	
Describe scope of work involved in building system upgrades and or replacements, HVAC systems, electrical, Sprinkler, etc. New construction	
Describe existing and or new work for fire detection, alarm, and communication systems: New construction	
If a hospital or nursing home located in a flood zone, provide a FEMA BFE Certificate from <a href="http://www.fema.gov">www.fema.gov</a> , and describe the work to mitigate damage and maintain operations during a flood event. N/A	
Does the project contain imaging equipment used for diagnostic or treatment purposes? If yes, describe the equipment to be provided and or replaced. Ensure physicist's letter of certification and report are submitted. No Click here to enter text.	
Does the project comply with ADA? If no, list all areas of noncompliance. Yes	
Other pertinent information: Click here to enter text.	
Project Work Area	Response
Type of Work	Alteration
Square footages of existing areas, existing floor and or existing building.	44,992 sf building
Square footages of the proposed work area or areas. Provide the aggregate sum of the work areas.	8,059 sf
Does the work area exceed more than 50% of the smoke compartment, floor or building?	Less than 50% of the building
Sprinkler protection per NFPA 101 Life Safety Code	Will be sprinklered as part of the work.
Construction Type per NFPA 101 Life Safety Code and NFPA 220	Type II (000)
Building Height	22'-6"

# New York State Department of Health Certificate of Need Application

## Schedule 6

Building Number of Stories	1
Which edition of FGI is being used for this project?	2018 Edition of FGI
Is the proposed work area located in a basement or underground building?	Not Applicable
Is the proposed work area within a windowless space or building?	No
Is the building a high-rise?	No
If a high-rise, does the building have a generator?	Not Applicable
What is the Occupancy Classification per NFPA 101 Life Safety Code?	Chapter 20 New Ambulatory Health Care Occupancy
Are there other occupancy classifications that are adjacent to or within this facility? If yes, what are the occupancies and identify these on the plans. Business	Yes
Will the project construction be phased? If yes, how many phases and what is the duration for each phase? N/A	No
Does the project contain shell space? If yes, describe proposed shell space and identify Article 28 and non-Article 28 shell space on the plans. N/A	No
Will spaces be temporarily relocated during the construction of this project? If yes, where will the temporary space be? N/A	No
Does the temporary space meet the current DOH referenced standards? If no, describe in detail how the space does not comply. N/A	Not Applicable
Is there a companion CON associated with the project or temporary space? If so, provide the associated CON number. N/A	Not Applicable
Will spaces be permanently relocated to allow the construction of this project? If yes, where will this space be? N/A	No
Changes in bed capacity? If yes, enumerate the existing and proposed bed capacities. N/A	Not Applicable
Changes in the number of occupants? If yes, what is the new number of occupants? N/a	Not Applicable
Does the facility have an Essential Electrical System (EES)? If yes, which EES Type? 1	Yes
If an existing EES Type 1, does it meet NFPA 99 -2012 standards?	Not Applicable
Does the existing EES system have the capacity for the additional electrical loads? N/A	Not Applicable
Does the project involve Operating Room alterations, renovations, or rehabilitation? If yes, provide brief description. N/A	No
Does the project involve Bulk Oxygen Systems? If yes, provide brief description. NA	No
If existing, does the Bulk Oxygen System have the capacity for additional loads without bringing in additional supplemental systems?	Not Applicable
Does the project involve a pool?	No

REQUIRED ATTACHMENT TABLE			
SCHEMATIC DESIGN SUBMISSION for CONTINGENT APPROVAL	DESIGN DEVELOPMENT SUBMISSION (State Hospital Code Submission) for CONTINGENCY SATISFACTION	Title of Attachment	File Name in PDF format
•		Architectural/Engineering Narrative	A/E Narrative.PDF
•		Functional Space Program	FSP.PDF
•		Architect/Engineer Certification Form	A/E Cert Form. PDF
•		FEMA BFE Certificate	FEMA BFE Cert.PDF
•		Article 28 Space/Non-Article 28 Space Plans	CON100.PDF
•	•	Site Plans	SP100.PDF
•	•	Life Safety Plans including level of exit discharge, and NFPA 101-2012 Code Analysis	LSC100.PDF
•	•	Architectural Floor Plans, Roof Plans and Details. Illustrate FGI compliance on plans.	A100.PDF
•	•	Exterior Elevations and Building Sections	A200.PDF
•	•	Vertical Circulation	A300.PDF
•	•	Reflected Ceiling Plans	A400.PDF
optional	•	Wall Sections and Partition Types	A500.PDF
optional	•	Interior Elevations, Enlarged Plans and Details	A600.PDF
	•	Fire Protection	FP100.PDF
	•	Mechanical Systems	M100.PDF
	•	Electrical Systems	E100.PDF
	•	Plumbing Systems	P100.PDF
	•	Physicist's Letter of Certification and Report	X100.PDF

**ENDOSCOPY CENTER OF WESTERN NEW YORK, LLC**

**SCHEDULE 6 ATTACHMENTS**

- 1. Architect / Applicant Letter of Certification**
- 2. Functional Space Program**
- 3. Environmental Assessment Form**
- 4. Schematic Plans**



CONSTRUCTION PROJECT CERTIFICATION LETTER FOR AER REVIEWS ARCHITECTS & ENGINEERS

(For projects not meeting the prerequisites for Self-Certification submission.)

Date: 6/19/24
CON Number: TBD
Facility Name: Medical Office Building
Facility ID Number: TBD
Facility Address: Windward Rd, Orchard Park, NY 14127

NYS Department of Health/Office of Health Systems Management
Center for Health Care Facility Planning, Licensure, and Finance
Bureau of Architectural and Engineering Review
ESP, Corning Tower, 18th Floor
Albany, New York 12237

To The New York State Department of Health:

I hereby certify that:

- 1. I have been retained by the aforementioned facility, to provide professional architectural/engineering services related to the design and preparation of construction documents...
2. I have ascertained that, to the best of my knowledge, information and belief, the completed structure will be designed and constructed...
3. The above-referenced construction project will be designed and constructed in compliance with all applicable local codes...
a. 712 (Standards of Construction for General Hospital Facilities)
b. 713 (Standards of Construction for Nursing Home Facilities)
c. 714 (Standards of Construction for Adult Day Health Care Program Facilities)
d. X 715 (Standards of Construction for Freestanding Ambulatory Care Facilities)
e. 716 (Standards of Construction for Rehabilitation Facilities)
f. 717 (Standards of Construction for New Hospice Facilities and Units)

PLEASE NOTE ANY EXCEPTIONS HERE:

\_\_\_\_\_

- 4. I understand that as the design of this project progresses, if a component of this project is inconsistent with the State Hospital Code (10 NYCRR Parts 711, 712, 713, 714, 715, 716, or 717), I shall bring this to the attention of the Bureau of Architecture and Engineering Review (BAER) of the New York State Department of Health prior to or upon submitting final drawings for compliance resolution.

5. I understand that upon completion of construction, the costs of any subsequent corrections necessary to achieve compliance with applicable requirements of 10 NYCRR Parts 711, 712, 713, 714, 715, 716 and 717, when the prior work was not completed properly as certified herein, may not be considered allowable costs for reimbursement under 10 NYCRR Part 86.

This certification is being submitted to facilitate the CON review and subsequent to formal plan approval by your office. It is understood that an electronic copy of final Construction Documents on CD, meeting the requirements of DSG-05 must be submitted to PMU for all projects, including limited, administrative, full review, self-certification and reviews performed and completed by DASNY.

**Project Name:** Medical Office Building

**Location:** Windward Rd. (SBL 152.18-2-6) Orchard Park, NY 14127

**Description:** 8,059 sf GI surgery center with three procedure rooms, and associated pre-op and recovery bays and support spaces, within a new construction 1 story ~45,000 sf medical office building.



*Philip J. Silvestri*  
 \_\_\_\_\_  
 Signature of Architect or Engineer

Philip J. Silvestri  
 \_\_\_\_\_  
 Name of Architect or Engineer (Print)

015518  
 \_\_\_\_\_  
 Professional New York State License Number

1321 Millersport Hwy Suite 101, Amherst, NY 14132  
 \_\_\_\_\_  
 Business Address

The undersigned applicant understands and agrees that, notwithstanding this architectural/engineering certification the Department of Health shall have continuing authority to (a) review the plans submitted herewith and/or inspect the work with regard thereto, and (b) withdraw its approval thereto. The applicant shall have a continuing obligation to make any changes required by the Division to comply with the above-mentioned codes and regulations, whether or not physical plant construction or alterations have been completed.

*Ann Sariego* 

\_\_\_\_\_  
 Authorized Signature for Applicant

Ann Sariego

Market President

11/05/2024 12:49 PM EST

\_\_\_\_\_  
 Date

\_\_\_\_\_  
 Name (Print)

\_\_\_\_\_  
 Title

*Notary signing required for the applicant*

STATE OF NEW YORK )

County of Nassau )

) SS:  
 )

On the 5th day of November 2024, before me personally appeared Ann Sariego, to me known, who being by me duly sworn, did depose and say that he/she is the Authorized Signer of the \_\_\_\_\_

\_\_\_\_\_, the facility described herein which executed the foregoing instrument; and that he/she signed his/her name thereto by order of the governing authority of said facility.

*Joanne M. DeAngelis* 

11/05/2024 12:51 PM EST

(Notary) \_\_\_\_\_

Joanne M. DeAngelis  
 NOTARY PUBLIC, STATE OF NEW YORK  
 Registration No. 01DE0016176  
 Qualified in Nassau County  
 Commission Expires November 11, 2027

Online Notary Public. This notarial act involved the use of online audio/video communication technology. Nolarization facilitated by SIGNiX®

ARCHITECTURAL AND ENGINEERING LETTER OF CERTIFICATION



GI Surgical Center  
 45 Windward Road  
 Orchard Park, NY 14127

CON #

Administration/Common Area	Qty	Net SF	Total SF
Reception / Waiting	1	954	954
Vestibule	1	107	107
Wheelchair Storage at Vestibule	1	26	26
Waiting Room Toilet	1	73	73
<b>Staff Areas</b>			
Office 1	1	103	103
Office 2	1	111	111
IT	1	84	84
Staff Break Room	1	182	182
Men's Locker/ Toilet Room	1	179	179
Women's Locker/ Toilet Room	1	232	232
Staff Toilet	1	68	68
<b>Equipment Rooms</b>			
Electrical Room	1	107	107
Mechanical Room 1	1	94	94
Mechanical Room 2	1	18	18
Total Sq Ft			2,338
Area Circlation			405
Total Admin/Common Area Gross Sq Ft			2,743

Procedure	Qty	Net SF	Total SF
Consultation Room	1	123	123
Equipment Storage 1	1	7	7
Equipment Storage 2	1	10	10
Med's Room	1	79	79
Nurses Station	2	82	164
Patient Toilet 1	1	64	64
Patient Toilet 2	1	67	67
Nutrition	1	19	19
Soiled Hold	1	80	80
Supply Storage	1	66	66
Pre-Op/ Post-Op Patient Bay 1	4	91	364
Pre-Op/ Post-Op Patient Bay 2	2	100	200
Pre-Op/ Post-Op Patient Bay 3	3	95	285
Exam/Pre-Op	1	169	169
Environmental Services	1	40	40
Hand Wash Station 1	1	15	15
Hand Wash Station 1	1	7	7
<b>Procedure Area</b>			
Procedure Room 1	2	296	592
Procedure Room 1	1	302	302
Dictation Area	3	16	48
Supply Room	1	99	99
Clean Linen	1	98	98

GI Surgical Center  
45 Windward Road  
Orchard Park, NY 14127

CON #

**Instrument Rooms**

Soiled Scope/Decontamination	1	155	155
Scope Processing	1	201	201

**Maintenance/ Delivery**

Environmental Services	1	69	69
Med Gas	1	82	82
Hazardous Waste	1	47	47
Break Down Area	1	144	144

---

Total Sq Ft			3,596
Area Circulation			1,720
Total Procedure Gross Sq Ft			5,316

---

Total Sq Ft			8,059
Building Shell Sq Ft			222
Total Net Sq Ft			8,281

# Short Environmental Assessment Form

## Part 1 - Project Information

### Instructions for Completing

**Part 1 – Project Information.** The applicant or project sponsor is responsible for the completion of Part 1. Responses become part of the application for approval or funding, are subject to public review, and may be subject to further verification. Complete Part 1 based on information currently available. If additional research or investigation would be needed to fully respond to any item, please answer as thoroughly as possible based on current information.

Complete all items in Part 1. You may also provide any additional information which you believe will be needed by or useful to the lead agency; attach additional pages as necessary to supplement any item.

<b>Part 1 – Project and Sponsor Information</b>			
Name of Action or Project: Proposed Medical Office Building			
Project Location (describe, and attach a location map): Windward Rd (SBL 152.18-2-6) Town of Orchard Park Erie County			
Brief Description of Proposed Action: The 45,000 sf 1-story medical building project is located on the north side of Windward Road, across from 480 Redtail Road. The site is currently vacant. The site is bordered on all sides by existing I-1 zoned property. The overall property area is approximately 4.288 acres.			
Name of Applicant or Sponsor: OPSP LLC c/o Christoipher Wood, PE Carmina Wood Design		Telephone: 716-550-3342 E-Mail: cwood@carminawooddesign.com	
Address: 487 Main St			
City/PO: Buffalo		State: NY	Zip Code: 14203
1. Does the proposed action only involve the legislative adoption of a plan, local law, ordinance, administrative rule, or regulation? If Yes, attach a narrative description of the intent of the proposed action and the environmental resources that may be affected in the municipality and proceed to Part 2. If no, continue to question 2.			NO <input type="checkbox"/>
2. Does the proposed action require a permit, approval or funding from any other government Agency? If Yes, list agency(s) name and permit or approval: NYSDEC SPDES, Erie County DSM, ECWA			YES <input checked="" type="checkbox"/>
3. a. Total acreage of the site of the proposed action? _____ 4.288 acres b. Total acreage to be physically disturbed? _____ 4.288 acres c. Total acreage (project site and any contiguous properties) owned or controlled by the applicant or project sponsor? _____ 4.288 acres			
4. Check all land uses that occur on, are adjoining or near the proposed action:			
5. <input type="checkbox"/> Urban <input type="checkbox"/> Rural (non-agriculture) <input checked="" type="checkbox"/> Industrial <input checked="" type="checkbox"/> Commercial <input type="checkbox"/> Residential (suburban) <input type="checkbox"/> Forest <input type="checkbox"/> Agriculture <input type="checkbox"/> Aquatic <input type="checkbox"/> Other(Specify): <input type="checkbox"/> Parkland			

<p>5. Is the proposed action,</p> <p>a. A permitted use under the zoning regulations?</p> <p>b. Consistent with the adopted comprehensive plan?</p>	<p>NO</p> <p><input type="checkbox"/></p> <p><input type="checkbox"/></p>	<p>YES</p> <p><input checked="" type="checkbox"/></p> <p><input checked="" type="checkbox"/></p>	<p>N/A</p> <p><input type="checkbox"/></p> <p><input type="checkbox"/></p>
<p>6. Is the proposed action consistent with the predominant character of the existing built or natural landscape?</p>	<p>NO</p> <p><input type="checkbox"/></p>	<p>YES</p> <p><input checked="" type="checkbox"/></p>	
<p>7. Is the site of the proposed action located in, or does it adjoin, a state listed Critical Environmental Area?</p> <p>If Yes, identify: _____</p>	<p>NO</p> <p><input checked="" type="checkbox"/></p>	<p>YES</p> <p><input type="checkbox"/></p>	
<p>8. a. Will the proposed action result in a substantial increase in traffic above present levels?</p> <p>b. Are public transportation services available at or near the site of the proposed action?</p> <p>c. Are any pedestrian accommodations or bicycle routes available on or near the site of the proposed action?</p>	<p>NO</p> <p><input checked="" type="checkbox"/></p> <p><input checked="" type="checkbox"/></p> <p><input checked="" type="checkbox"/></p>	<p>YES</p> <p><input type="checkbox"/></p> <p><input type="checkbox"/></p> <p><input type="checkbox"/></p>	
<p>9. Does the proposed action meet or exceed the state energy code requirements?</p> <p>If the proposed action will exceed requirements, describe design features and technologies:</p> <p>_____</p> <p>_____</p>	<p>NO</p> <p><input type="checkbox"/></p>	<p>YES</p> <p><input checked="" type="checkbox"/></p>	
<p>10. Will the proposed action connect to an existing public/private water supply?</p> <p>If No, describe method for providing potable water: _____</p> <p>_____</p>	<p>NO</p> <p><input type="checkbox"/></p>	<p>YES</p> <p><input checked="" type="checkbox"/></p>	
<p>11. Will the proposed action connect to existing wastewater utilities?</p> <p>If No, describe method for providing wastewater treatment: _____</p> <p>_____</p>	<p>NO</p> <p><input type="checkbox"/></p>	<p>YES</p> <p><input checked="" type="checkbox"/></p>	
<p>12. a. Does the project site contain, or is it substantially contiguous to, a building, archaeological site, or district which is listed on the National or State Register of Historic Places, or that has been determined by the Commissioner of the NYS Office of Parks, Recreation and Historic Preservation to be eligible for listing on the State Register of Historic Places?</p> <p>b. Is the project site, or any portion of it, located in or adjacent to an area designated as sensitive for archaeological sites on the NY State Historic Preservation Office (SHPO) archaeological site inventory?</p>	<p>NO</p> <p><input checked="" type="checkbox"/></p> <p><input checked="" type="checkbox"/></p>	<p>YES</p> <p><input type="checkbox"/></p> <p><input type="checkbox"/></p>	
<p>13. a. Does any portion of the site of the proposed action, or lands adjoining the proposed action, contain wetlands or other waterbodies regulated by a federal, state or local agency?</p> <p>b. Would the proposed action physically alter, or encroach into, any existing wetland or waterbody?</p> <p>If Yes, identify the wetland or waterbody and extent of alterations in square feet or acres: _____</p> <p>Wetlands are not present on the project site</p> <p>_____</p> <p>_____</p>	<p>NO</p> <p><input type="checkbox"/></p> <p><input checked="" type="checkbox"/></p>	<p>YES</p> <p><input checked="" type="checkbox"/></p> <p><input type="checkbox"/></p>	

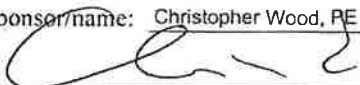
14. Identify the typical habitat types that occur on, or are likely to be found on the project site. Check all that apply: <input type="checkbox"/> Shoreline <input type="checkbox"/> Forest <input type="checkbox"/> Agricultural/grasslands <input type="checkbox"/> Early mid-successional <input type="checkbox"/> Wetland <input type="checkbox"/> Urban <input checked="" type="checkbox"/> Suburban		
15. Does the site of the proposed action contain any species of animal, or associated habitats, listed by the State or Federal government as threatened or endangered?	NO	YES
	<input checked="" type="checkbox"/>	<input type="checkbox"/>
16. Is the project site located in the 100-year flood plan?	NO	YES
	<input checked="" type="checkbox"/>	<input type="checkbox"/>
17. Will the proposed action create storm water discharge, either from point or non-point sources? If Yes,	NO	YES
a. Will storm water discharges flow to adjacent properties?	<input checked="" type="checkbox"/>	<input type="checkbox"/>
b. Will storm water discharges be directed to established conveyance systems (runoff and storm drains)? If Yes, briefly describe:	<input type="checkbox"/>	<input checked="" type="checkbox"/>
Storm water will be directed to the existing on-site storm water detention basin following the private on-site storm water management area. <del>Water will be conveyed through the Town of Orchard Park storm system to the existing basin.</del>		
18. Does the proposed action include construction or other activities that would result in the impoundment of water or other liquids (e.g., retention pond, waste lagoon, dam)? If Yes, explain the purpose and size of the impoundment:	NO	YES
Storm water management (bioretention), size TBD	<input type="checkbox"/>	<input checked="" type="checkbox"/>
19. Has the site of the proposed action or an adjoining property been the location of an active or closed solid waste management facility? If Yes, describe:	NO	YES
	<input checked="" type="checkbox"/>	<input type="checkbox"/>
20. Has the site of the proposed action or an adjoining property been the subject of remediation (ongoing or completed) for hazardous waste? If Yes, describe:	NO	YES
	<input checked="" type="checkbox"/>	<input type="checkbox"/>
<b>I CERTIFY THAT THE INFORMATION PROVIDED ABOVE IS TRUE AND ACCURATE TO THE BEST OF MY KNOWLEDGE</b>		
Applicant/sponsor name: <u>Christopher Wood, PE</u> Date: <u>5/10/23</u>		
Signature: <u></u> Title: <u>Project Engineer</u>		

# EAF Mapper Summary Report

Wednesday, May 10, 2023 2:33 PM

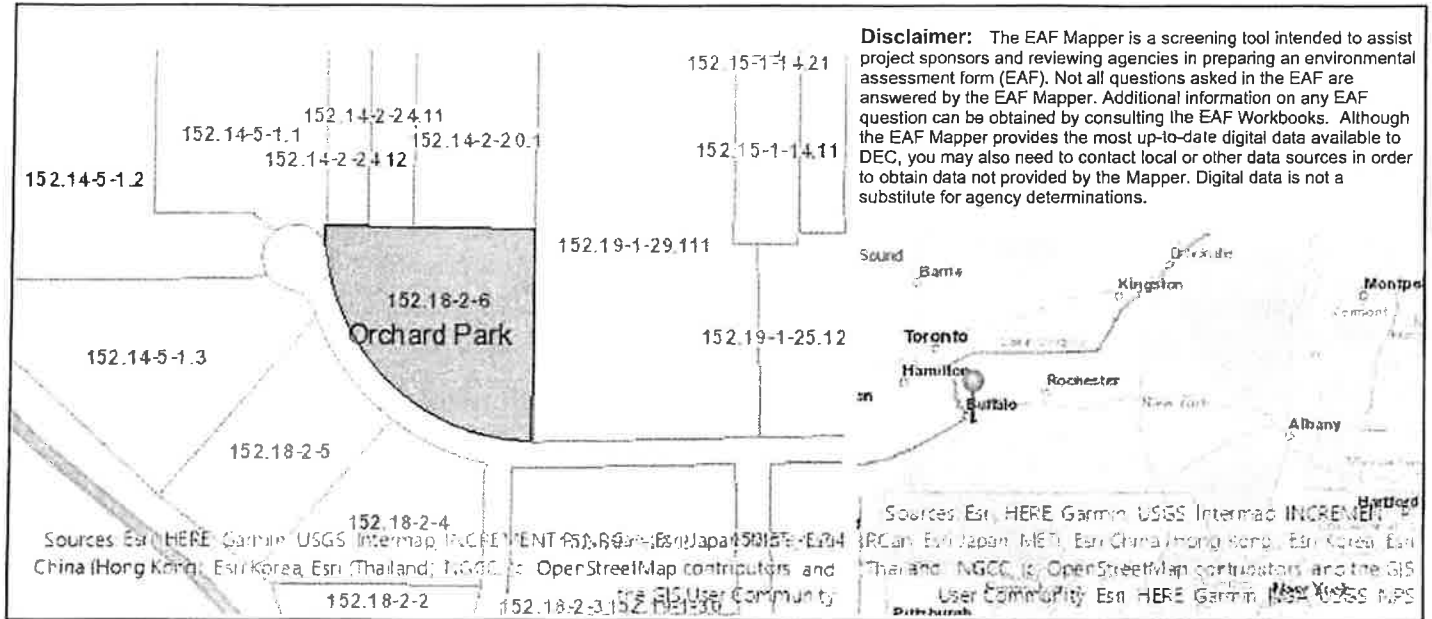

**Disclaimer:** The EAF Mapper is a screening tool intended to assist project sponsors and reviewing agencies in preparing an environmental assessment form (EAF). Not all questions asked in the EAF are answered by the EAF Mapper. Additional information on any EAF question can be obtained by consulting the EAF Workbooks. Although the EAF Mapper provides the most up-to-date digital data available to DEC, you may also need to contact local or other data sources in order to obtain data not provided by the Mapper. Digital data is not a substitute for agency determinations.

Part 1 / Question 7 [Critical Environmental Area]	No
Part 1 / Question 12a [National or State Register of Historic Places or State Eligible Sites]	No
Part 1 / Question 12b [Archeological Sites]	No
Part 1 / Question 13a [Wetlands or Other Regulated Waterbodies]	Yes - Digital mapping information on local and federal wetlands and waterbodies is known to be incomplete. Refer to EAF Workbook.
Part 1 / Question 15 [Threatened or Endangered Animal]	No
Part 1 / Question 16 [100 Year Flood Plain]	No
Part 1 / Question 20 [Remediation Site]	No

Sources: Esri, HERE, Garmin, USGS, Intermap, INCREMENT P, NOAA, Esri, Japan, Swisstopo, Esri, Canada, Esri, Japan, METI, Esri, China (Hong Kong), Esri, Korea, Esri, Thailand, Esri, Thailand, NGCC, Esri, OpenStreetMap contributors, and the GIS User Community. Esri, HERE, Garmin, USGS, NPS

**NOTICE**  
 This document, the property of, prepared and issued by the architect, is submitted for the specific project named \_\_\_\_\_ and the recipient by accepting this document assumes custody and agrees that this document will not be copied or reproduced in part or in whole, and any special features peculiar to this design shall not be incorporated in any other project, unless prior agreement has been obtained in writing. These documents will be returned immediately upon completion of the project or upon the request of the architect.  
 This document is the exclusive property of the architect, no rights to ownership are transferable, or shall be lost by the filing of this document with any and all public authorities for the purpose of compliance with Codes and or Ordinances, i.e. Building Permit, etc.

# Sterling 45 MOB - GI Surgical Tenant Fit Out

Sterling Business Park  
 Windward Road  
 Orchard Park, NY 14127

ISSUE:

SA PROJECT TEAM: PRINCIPAL P.Silvestri  
 INTERIORS A.Nagle JOB CAPT. J.Somes  
 DRAFTER J.Somes

SEAL:

TITLE:

## FLOOR PLAN



**SILVESTRI**  
 ARCHITECTS · PC

1321 MILLERSPORT HWY PH. 716.691.0900  
 AMHERST, NY 14221 FAX 716.691.4773

SA JOB #: 23020-02 DATE: 07-08-24

DRAWING #: A2-101

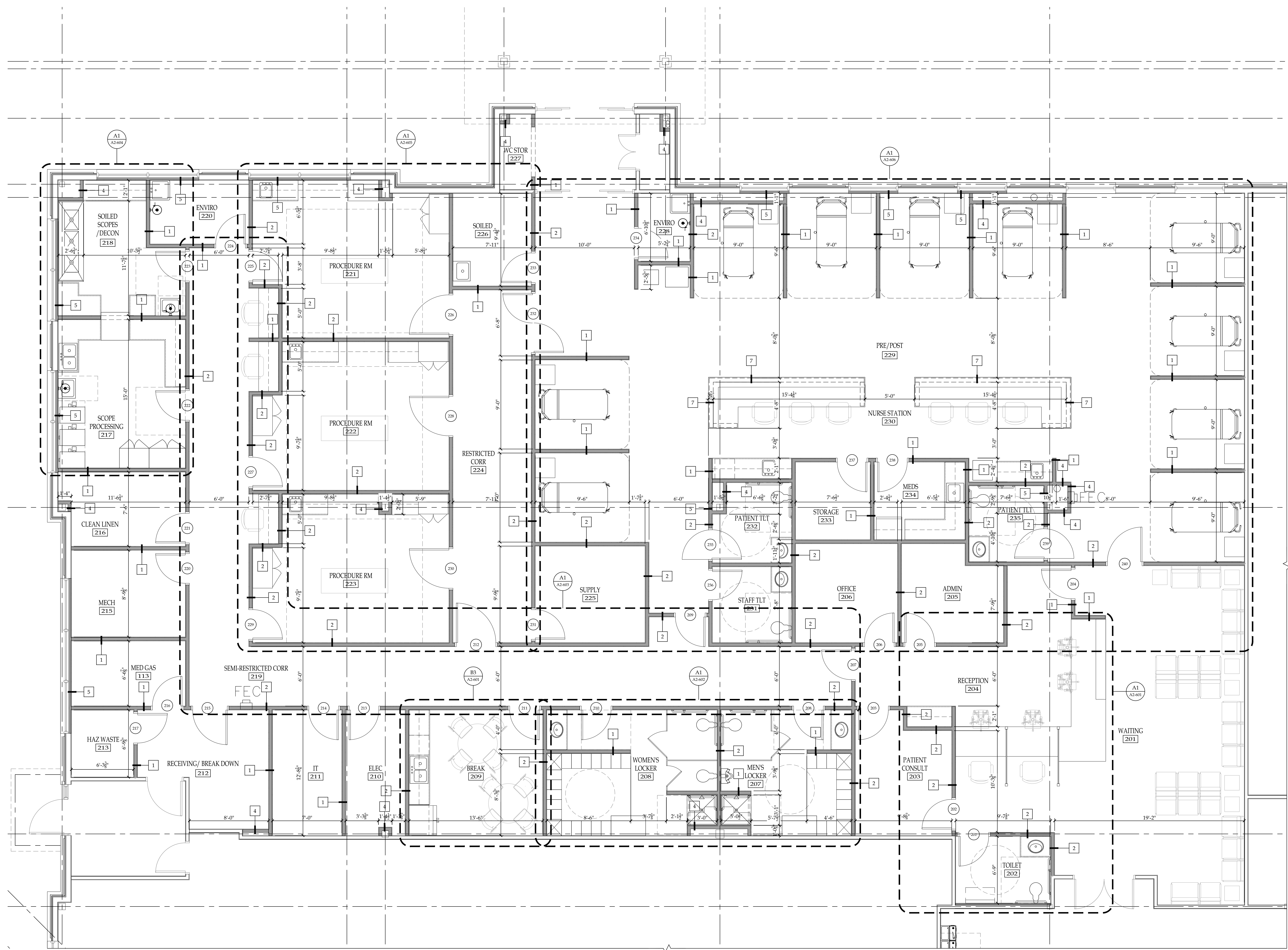

A1 FLOOR PLAN  
 1/4" = 1'-0"

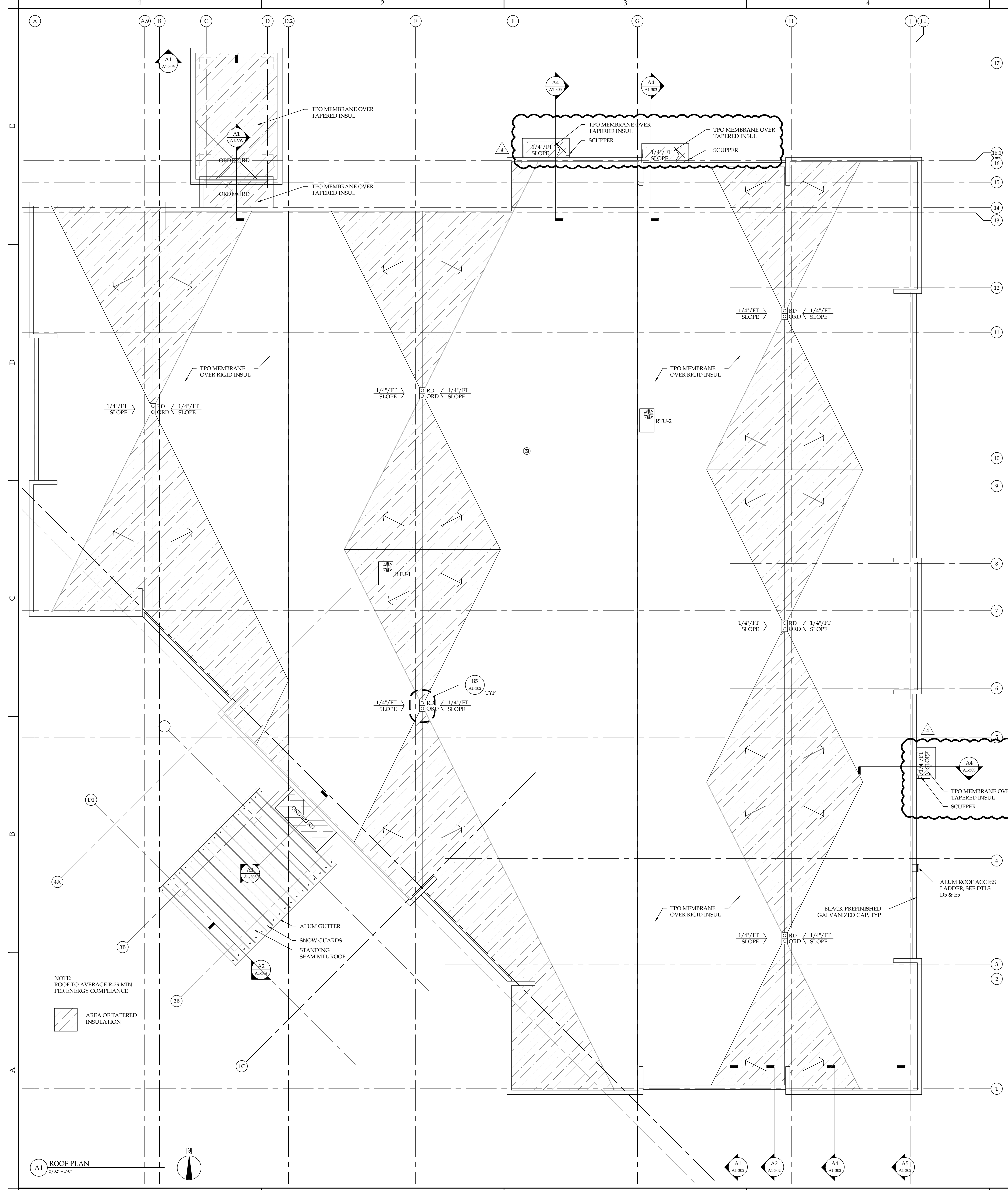

**ROOF PLAN GENERAL NOTES**

- THIS DRAWING SHALL BE COORDINATED WITH ALL MECHANICAL, PLUMBING, AND ELECTRICAL DRAWINGS. THE GENERAL CONTRACTOR SHALL BE RESPONSIBLE FOR THIS COORDINATION.
- ANY DISCREPANCIES IN DRAWINGS SHALL BE BROUGHT TO THE ATTENTION OF THE ARCHITECT.
- ALL ROOF PENETRATIONS TO BE PROPERLY FLASHED TO NOT ALLOW MOISTURE PENETRATION INTO STRUCTURE PER 2020 BUILDING CODE OF NYS SECTION 1503.

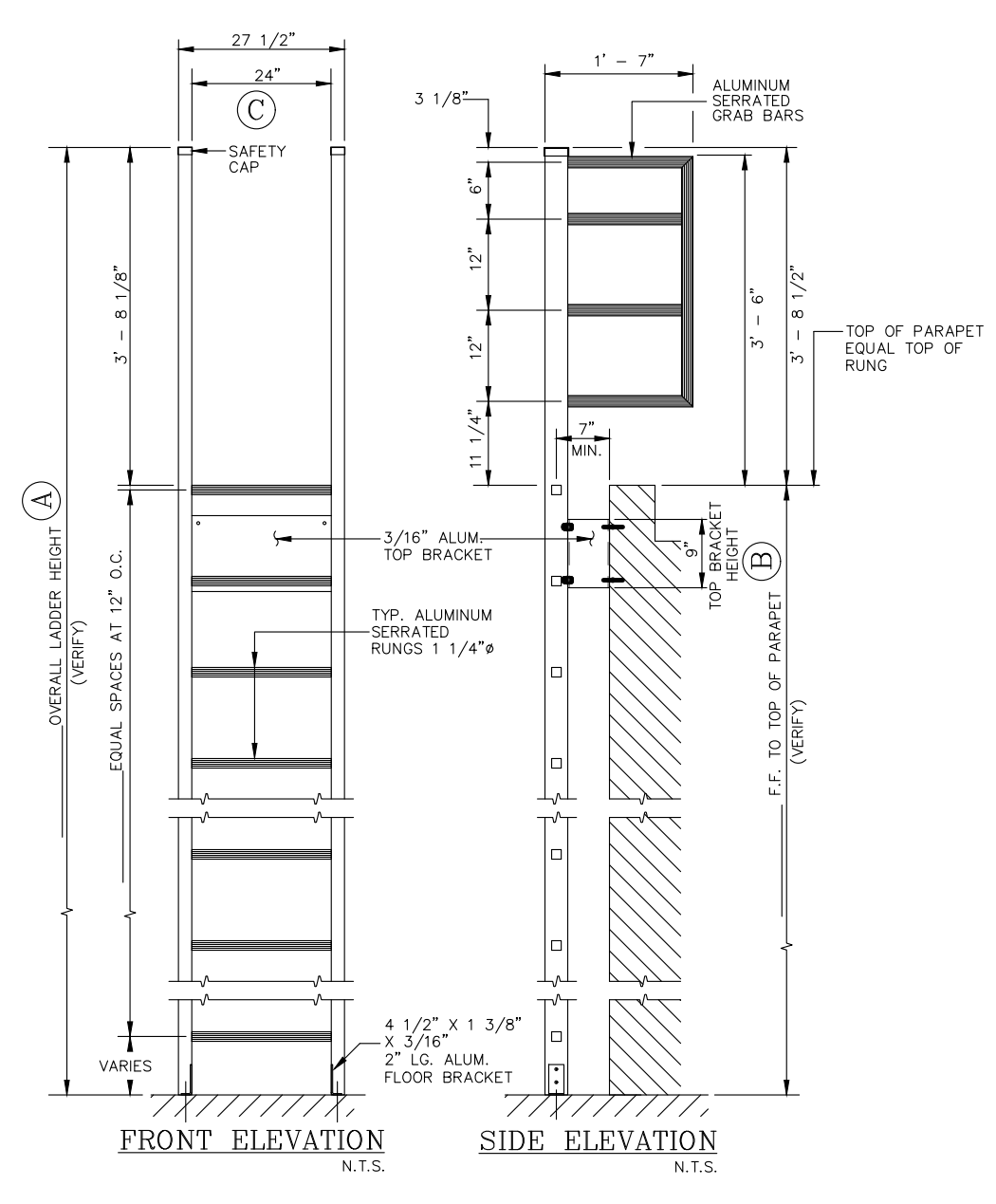

**E5 ROOF ACCESS LADDER DETAILS**  
SCALE: N.P.S.

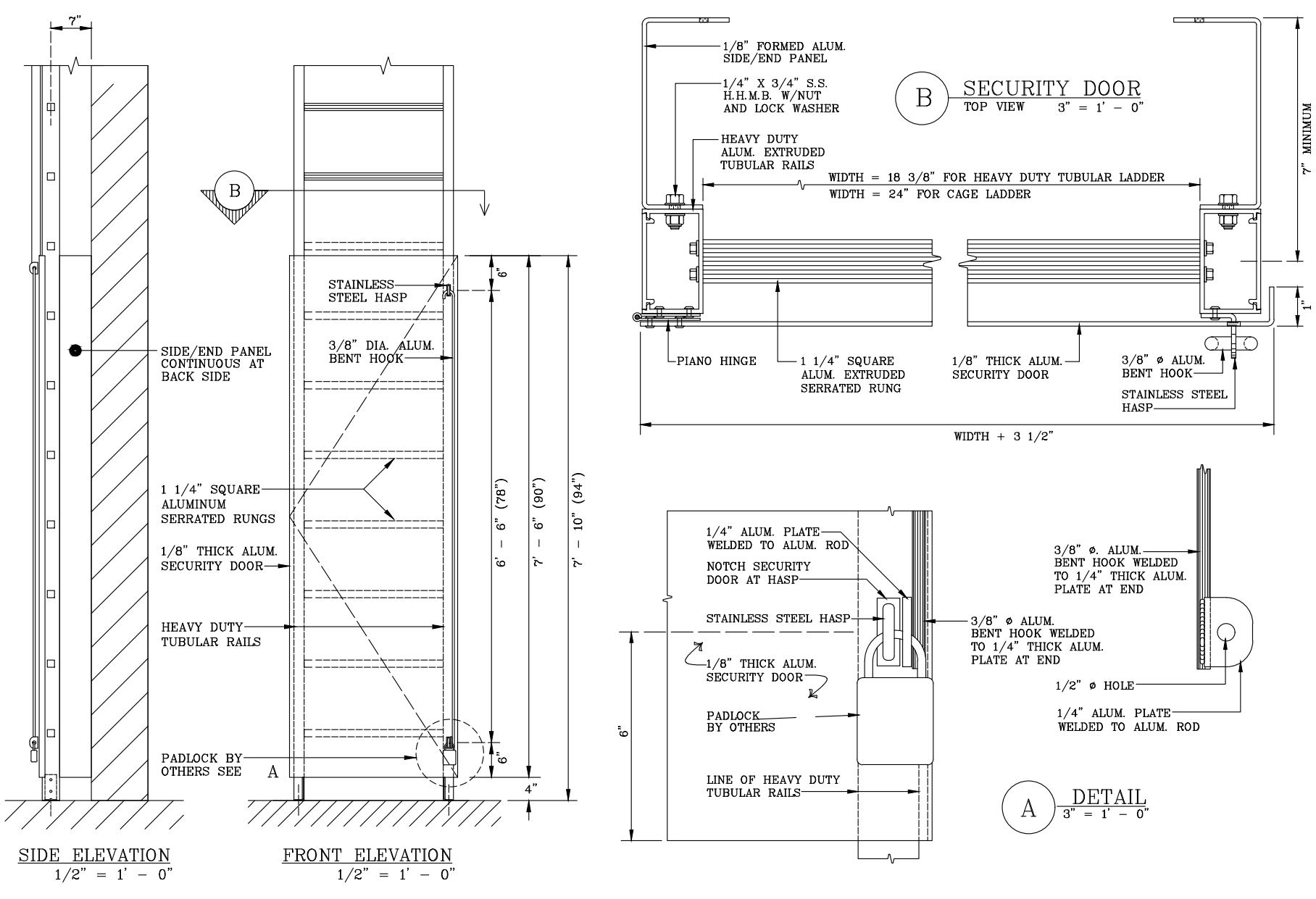

**D5 LADDER SECURITY DOOR DETAILS**  
SCALE: VARIOUS

**NOTES:**  
 1. PIPE MUST BE ANCHORED TO BOTTOM SIDE OF DECK TO ASSURE STABILITY.  
 2. DO NOT INSTALL CLAMPING RING AROUND TOP OF FORMFLASH. WOOD NAILER REQUIRED WHEN OUTSIDE.  
 3. DIAMETER OF THE PIPE EXCEEDS 18\"/>

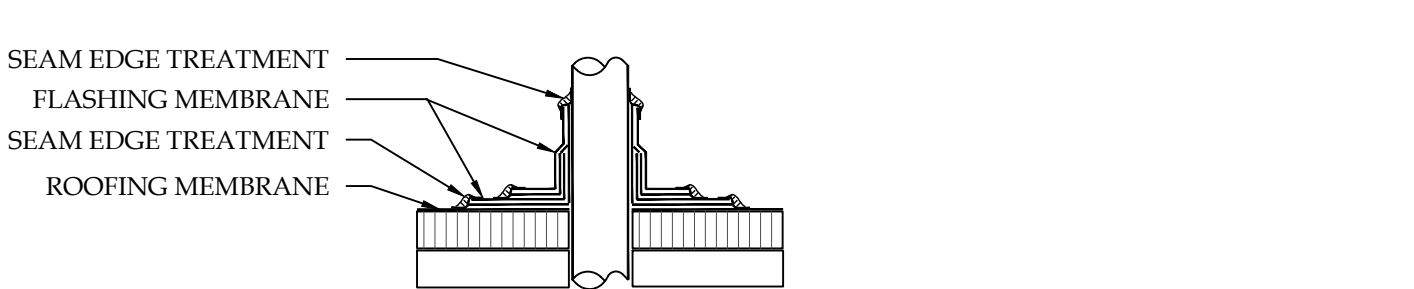

**C5 TYP. VENT DETAIL**  
SCALE: 1/2\"/>

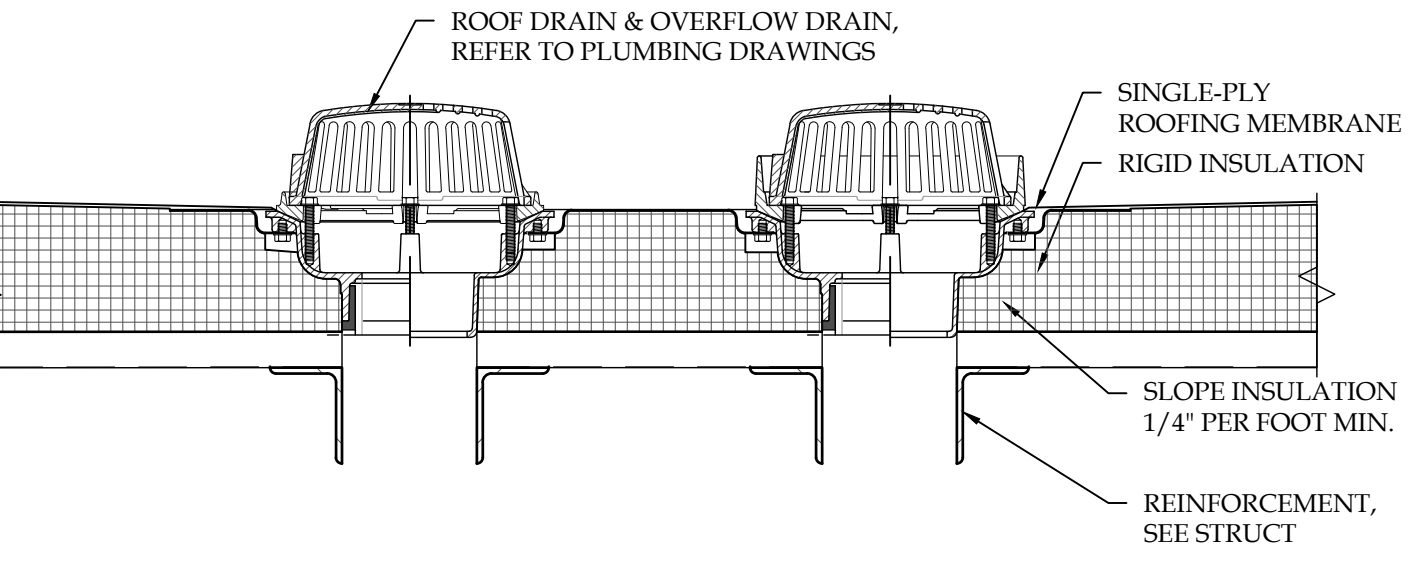

**B5 TYP. ROOF DRAIN DETAIL**  
SCALE: 1/2\"/>

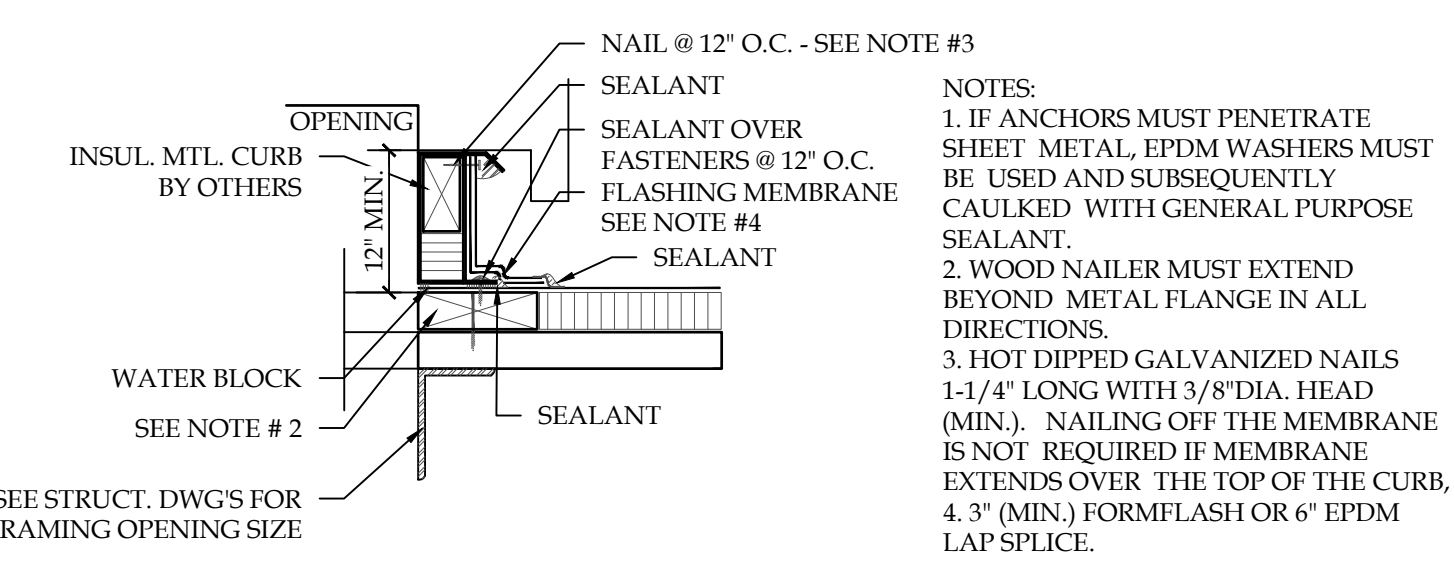

**A5 TYPICAL CURB DETAIL**  
SCALE: 1/2\"/>

**NOTICE**  
 This document, the property of, prepared and issued by the architect, is submitted for the specific project named \_\_\_\_\_ and the recipient by accepting this document assumes custody and agrees that this document will not be copied or reproduced in part or in whole, and any special features peculiar to this design shall not be incorporated in any other project, unless prior agreement has been obtained in writing. These documents will be returned immediately upon completion of the project or upon the request of the architect.  
 This document is the exclusive property of the architect, no rights to ownership are transferable, or shall be lost by the filing of this document with any and all public authorities for the purpose of compliance with Codes and or Ordinances, i.e. Building Permit, etc.

# Sterling 45 MOB - Shell

Sterling Business Park  
 Windward Road  
 Orchard Park, NY 14127

ISSUE: PERMIT SET 10-06-23  
 ADDENDUM 4 05-09-24

SA PROJECT TEAM: PRINCIPAL P.Silvestri  
 PROJ. ARCH. \_\_\_\_\_ JOB CAPT. J.Somes  
 INTERIORS A.Nagle \_\_\_\_\_ DRAFTER \_\_\_\_\_

SEAL:

TITLE:

## ROOF PLAN



**SILVESTRI ARCHITECTS · PC**

1321 MILLERSPORT HWY PH. 716.691.0900  
 AMHERST, NY 14221 FAX 716.691.4773

SA JOB #: 23020-01 DATE: 10-06-23

DRAWING #: A1-102



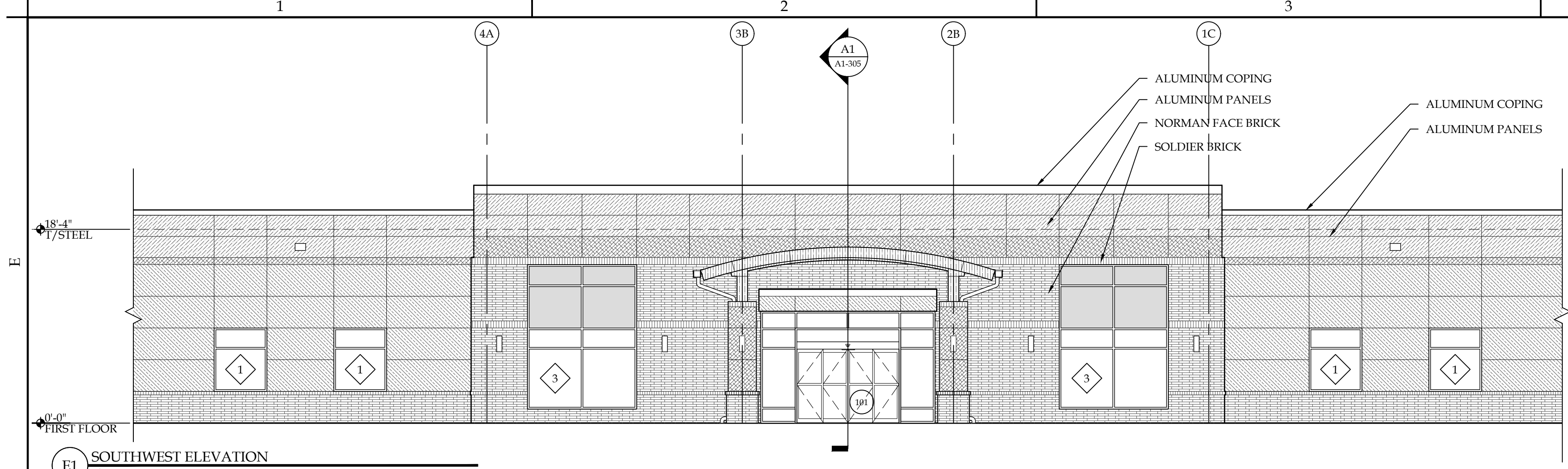

E1 SOUTHWEST ELEVATION  
1/8" = 1'-0"

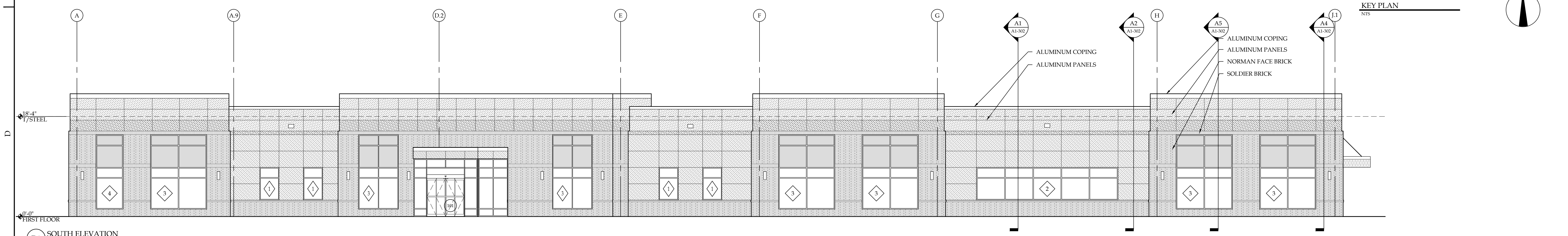

D1 SOUTH ELEVATION  
1/8" = 1'-0"

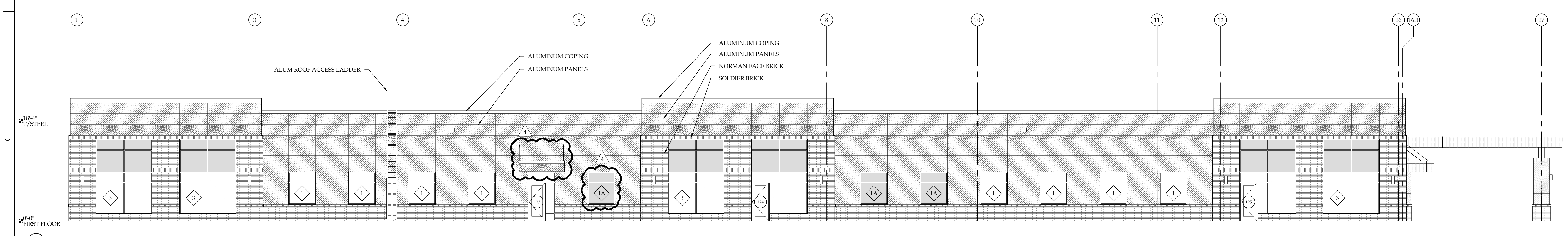

C1 EAST ELEVATION  
1/8" = 1'-0"

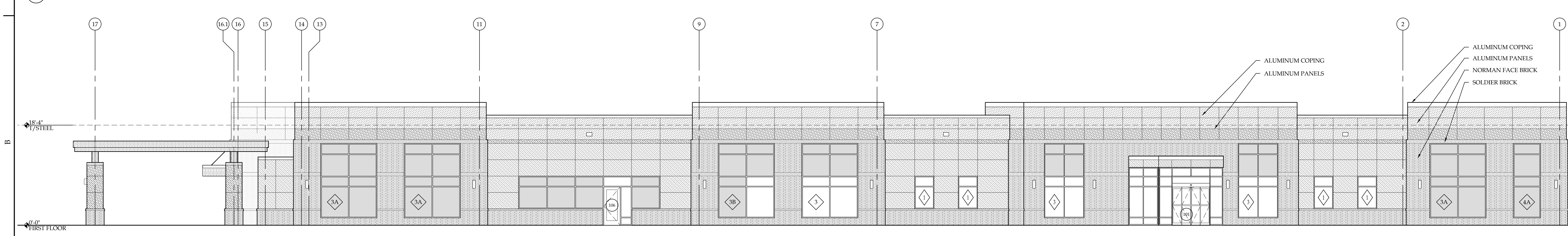

B1 WEST ELEVATION  
1/8" = 1'-0"

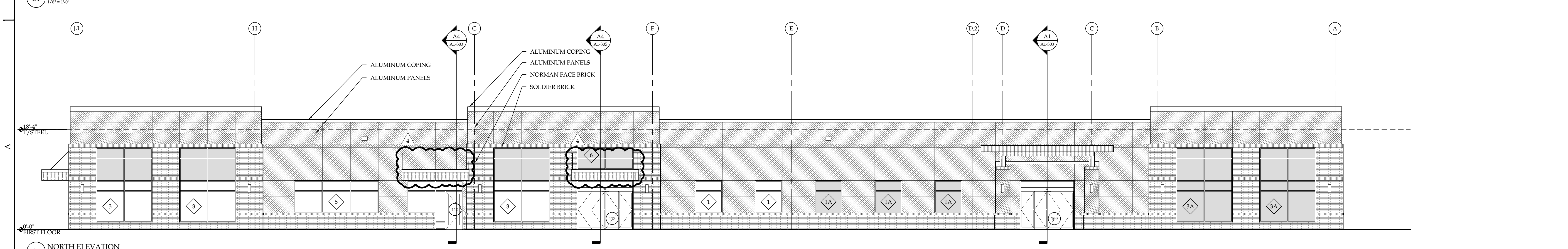

A1 NORTH ELEVATION  
1/8" = 1'-0"

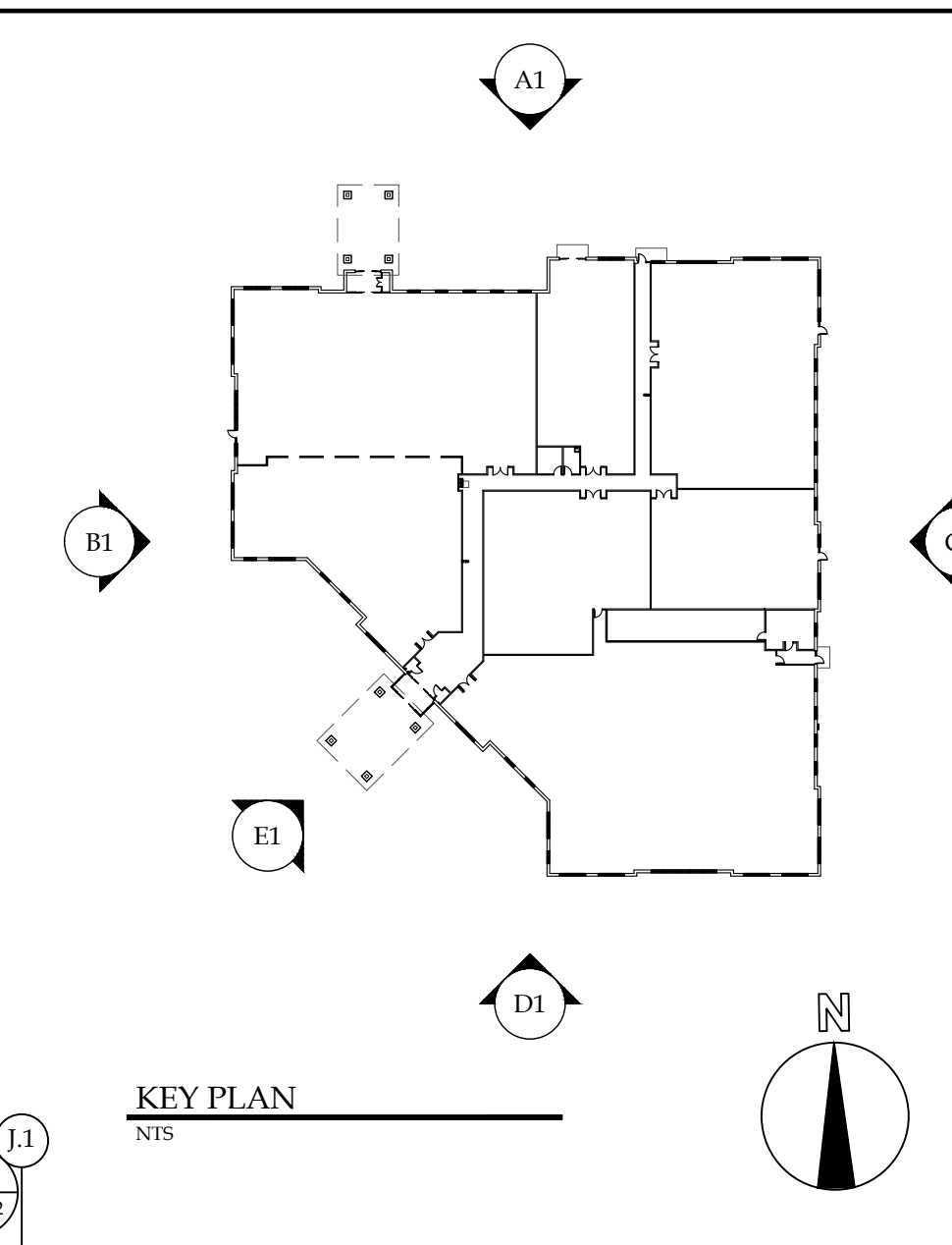

KEY PLAN  
NPS

**NOTICE**  
This document, the property of, prepared and issued by the architect, is submitted for the specific project named \_\_\_\_\_ and the recipient by accepting this document assumes custody and agrees that this document will not be copied or reproduced in part or in whole, and any special features peculiar to this design shall not be incorporated in any other project, unless prior agreement has been obtained in writing. These documents will be returned immediately upon completion of the project or upon the request of the architect.  
This document is the exclusive property of the architect, no rights to ownership are transferable, or shall be lost by the filing of this document with any and all public authorities for the purpose of compliance with Codes and or Ordinances, i.e. Building Permit, etc.

**Sterling 45  
MOB - Shell**  
  
Sterling Business Park  
Windward Road  
Orchard Park, NY 14127

ISSUE: PERMIT SET 10-06-23  
ADDENDUM 4 05-09-24

SA PROJECT TEAM: PRINCIPAL E.Silvestri  
PROJ. ARCH. \_\_\_\_\_ JOB CAPT. J.Somers  
INTERIORS A.Nagle \_\_\_\_\_ DRAFTER \_\_\_\_\_

SEAL:

TITLE:  
**EXTERIOR  
ELEVATIONS**



**SILVESTRI  
ARCHITECTS + PC**  
1321 MILLERSPORT HWY PH. 716.691.0900  
AMHERST, NY 14221 FAX 716.691.4773

SA JOB #: 23020-01 DATE: 10-06-23

DRAWING #: A-201

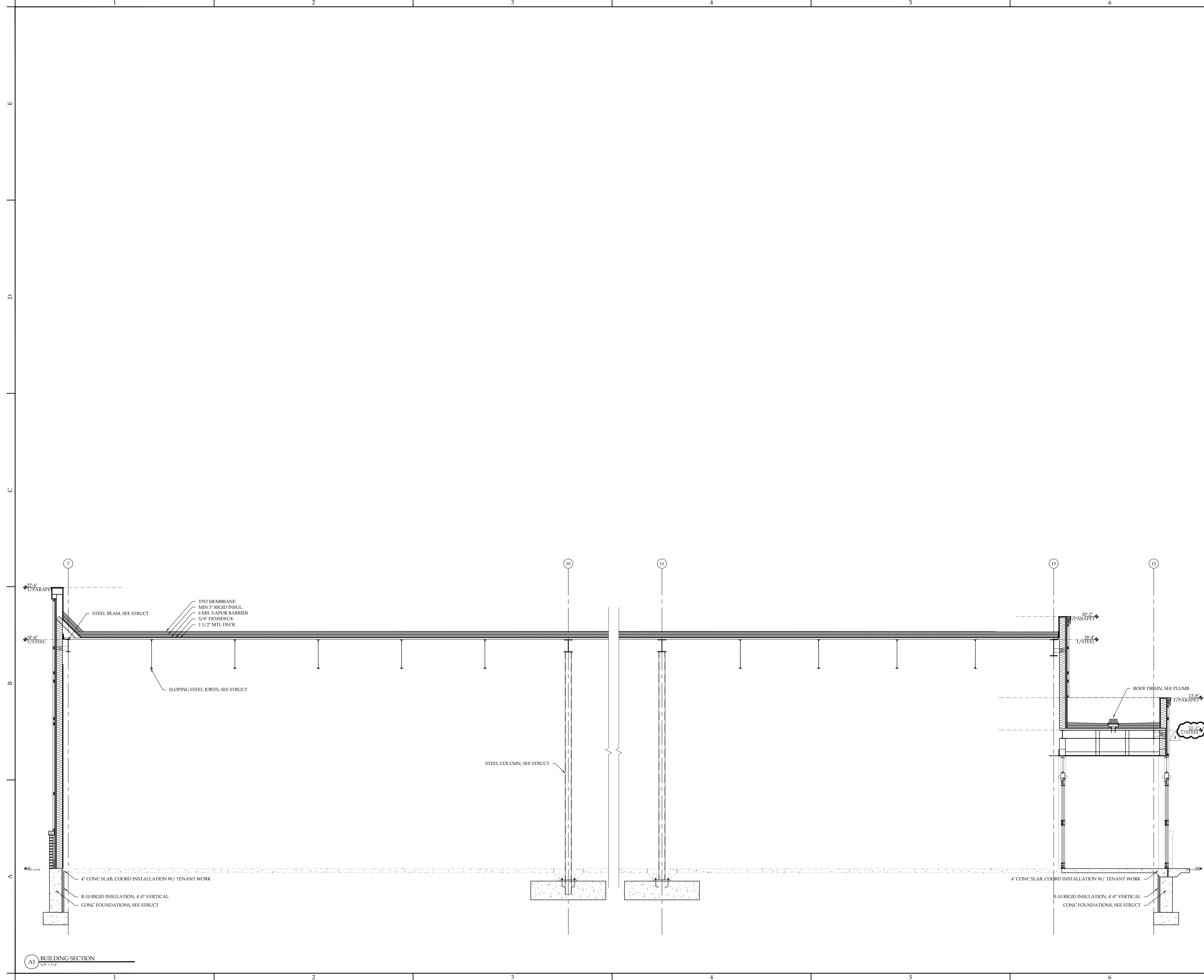

**NOTICE**  
 This document, the property of, prepared and issued by the architect, is submitted for the specific project named \_\_\_\_\_ and the recipient by accepting this document assumes custody and agrees that this document will not be copied or reproduced in part or in whole, and any special features peculiar to this design shall not be incorporated in any other project, unless prior agreement has been obtained in writing. These documents will be returned immediately upon completion of the project or upon the request of the architect.  
 This document is the exclusive property of the architect, no rights to ownership are transferable, or shall be lost by the filing of this document with any and all public authorities for the purpose of compliance with Codes and or Ordinances, i.e. Building Permit, etc.

**Sterling 45  
 MOB - Shell**

Sterling Business Park  
 Windward Road  
 Orchard Park, NY 14127

ISSUE: PERMIT SET 10-06-23  
 ADDENDUM 4 05-09-24

SA PROJECT TEAM: PRINCIPAL P.Silvestri  
 PROJ. ARCH. \_\_\_\_\_ JOB CAPT. J.Somers  
 INTERIORS A.Nagle \_\_\_\_\_ DRAFTER \_\_\_\_\_

SEAL:

TITLE:

**BUILDING SECTION**

**SILVESTRI  
 ARCHITECTS • PC**

1321 MILLERSPORT HWY PH. 716.691.0900  
 AMHERST, NY 14221 FAX 716.691.4773

SA JOB #: 23020-01 DATE: 10-06-23

DRAWING #: **A1-301**

A1 BUILDING SECTION  
 3/8" = 1'-0"

**NOTICE**  
 This document, the property of, prepared and issued by the architect, is submitted for the specific project and agrees that this document will not be copied or reproduced in part or in whole, and any special features peculiar to this design shall not be incorporated in any other project, unless prior agreement has been obtained in writing. These documents will be returned immediately upon completion of the project or upon the request of the architect.  
 This document is the exclusive property of the architect, no rights to ownership are transferable, or shall be lost by the filing of this document with any and all public authorities for the purpose of compliance with Codes and or Ordinances, i.e. Building Permit, etc.

# Sterling 45 MOB - Shell

Sterling Business Park  
 Windward Road  
 Orchard Park, NY 14127

ISSUE: PERMIT SET 10-06-23

SA PROJECT TEAM: PRINCIPAL P.Silvestri  
 PROJ. ARCH. \_\_\_\_\_ JOB CAPT. J.Somers  
 INTERIORS A.Nagle \_\_\_\_\_ DRAFTER \_\_\_\_\_

SEAL:

TITLE:

## WALL SECTIONS



**SILVESTRI**  
 ARCHITECTS · PC

1321 MILLERSPORT HWY PH. 716.691.0900  
 AMHERST, NY 14221 FAX 716.691.4773

SA JOB #: 23020-01 DATE: 10-06-23

DRAWING #: A1-302

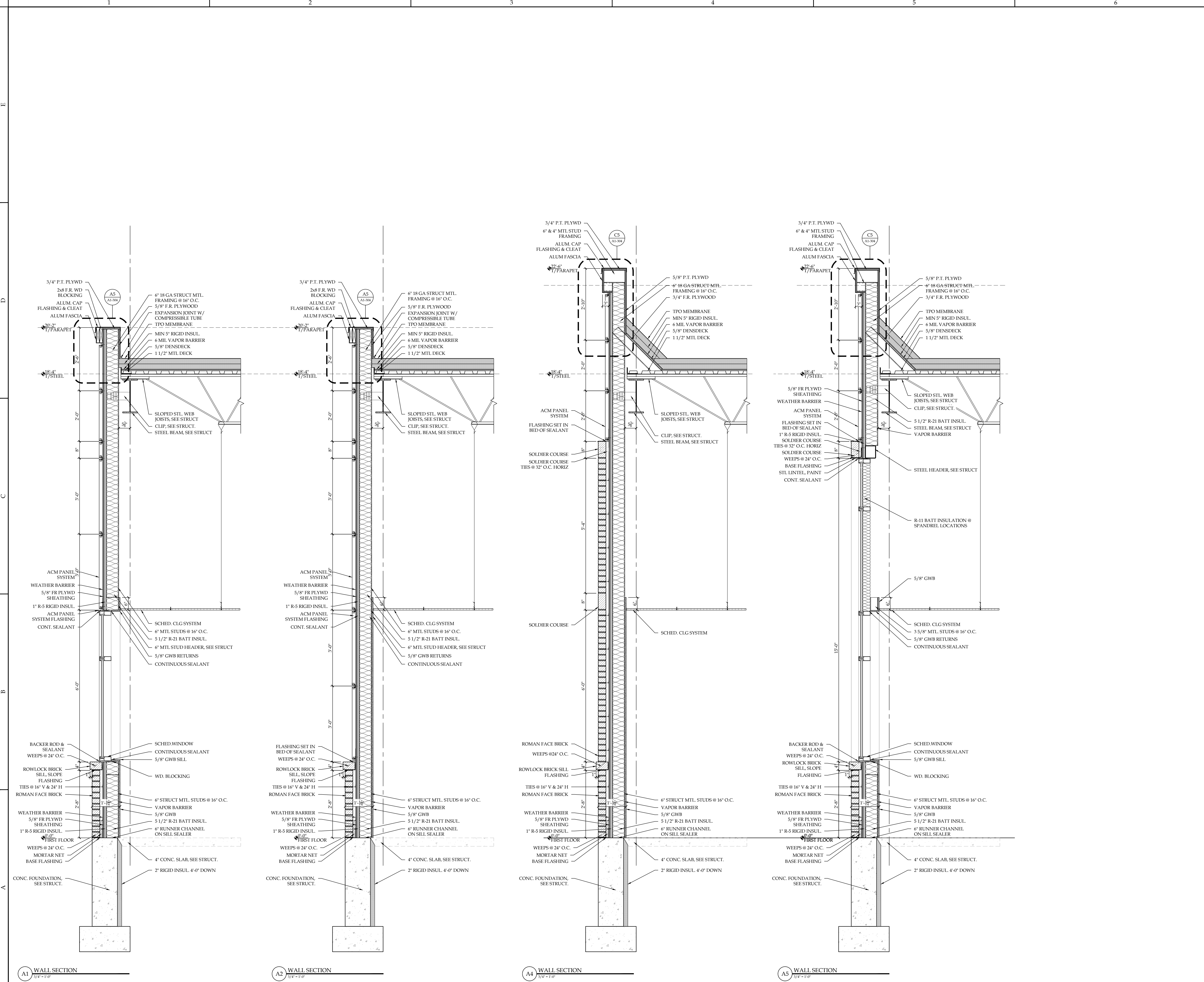

A1 WALL SECTION 3/4" x 1-0"  
 A2 WALL SECTION 3/4" x 1-0"  
 A4 WALL SECTION 3/4" x 1-0"  
 A5 WALL SECTION 3/4" x 1-0"

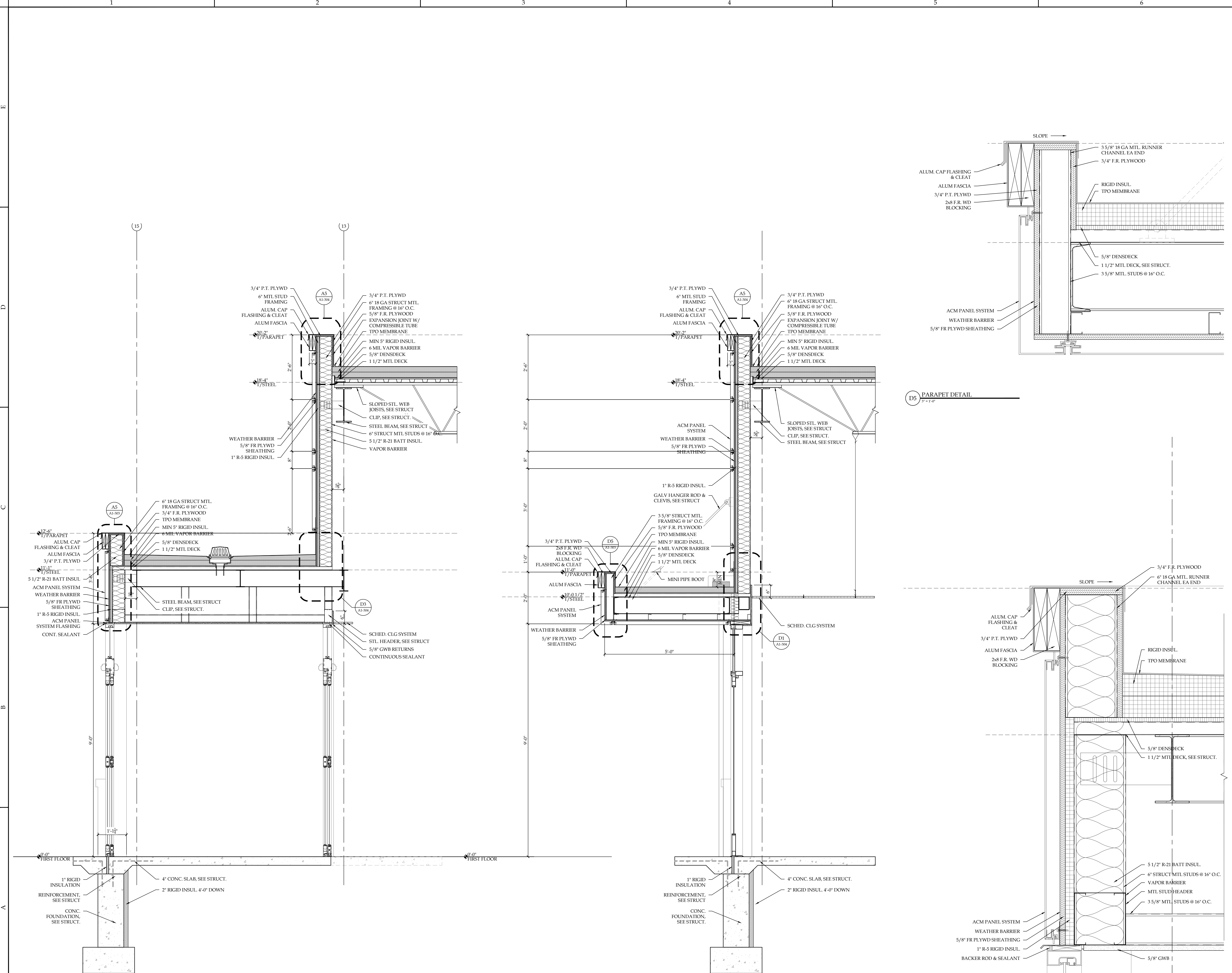

**NOTICE**  
 This document, the property of, prepared and issued by the architect, is submitted for the specific project and agrees that this document will not be copied or reproduced in part or in whole, and any special features peculiar to this design shall not be incorporated in any other project, unless prior agreement has been obtained in writing. These documents will be returned immediately upon completion of the project or upon the request of the architect.  
 This document is the exclusive property of the architect, no rights to ownership are transferable, or shall be lost by the filing of this document with any and all public authorities for the purpose of compliance with Codes and Ordinances.  
 I.e. Building Permit, etc.

**Sterling 45  
 MOB - Shell**

Sterling Business Park  
 Windward Road  
 Orchard Park, NY 14127

ISSUE: PERMIT SET 10-06-23

SA PROJECT TEAM: PRINCIPAL P.Silvestri  
 PROJ. ARCH. \_\_\_\_\_ JOB CAPT. J.Somers  
 INTERIORS A.Nagle \_\_\_\_\_ DRAFTER \_\_\_\_\_

SEAL:

**WALL  
 SECTIONS &  
 DETAILS**

**SILVESTRI  
 ARCHITECTS · PC**  
 1321 MILLERSPORT HWY PH. 716.691.0900  
 AMHERST, NY 14221 FAX 716.691.4773

SA JOB #: 23020-01 DATE: 10-06-23

DRAWING #: A1-303

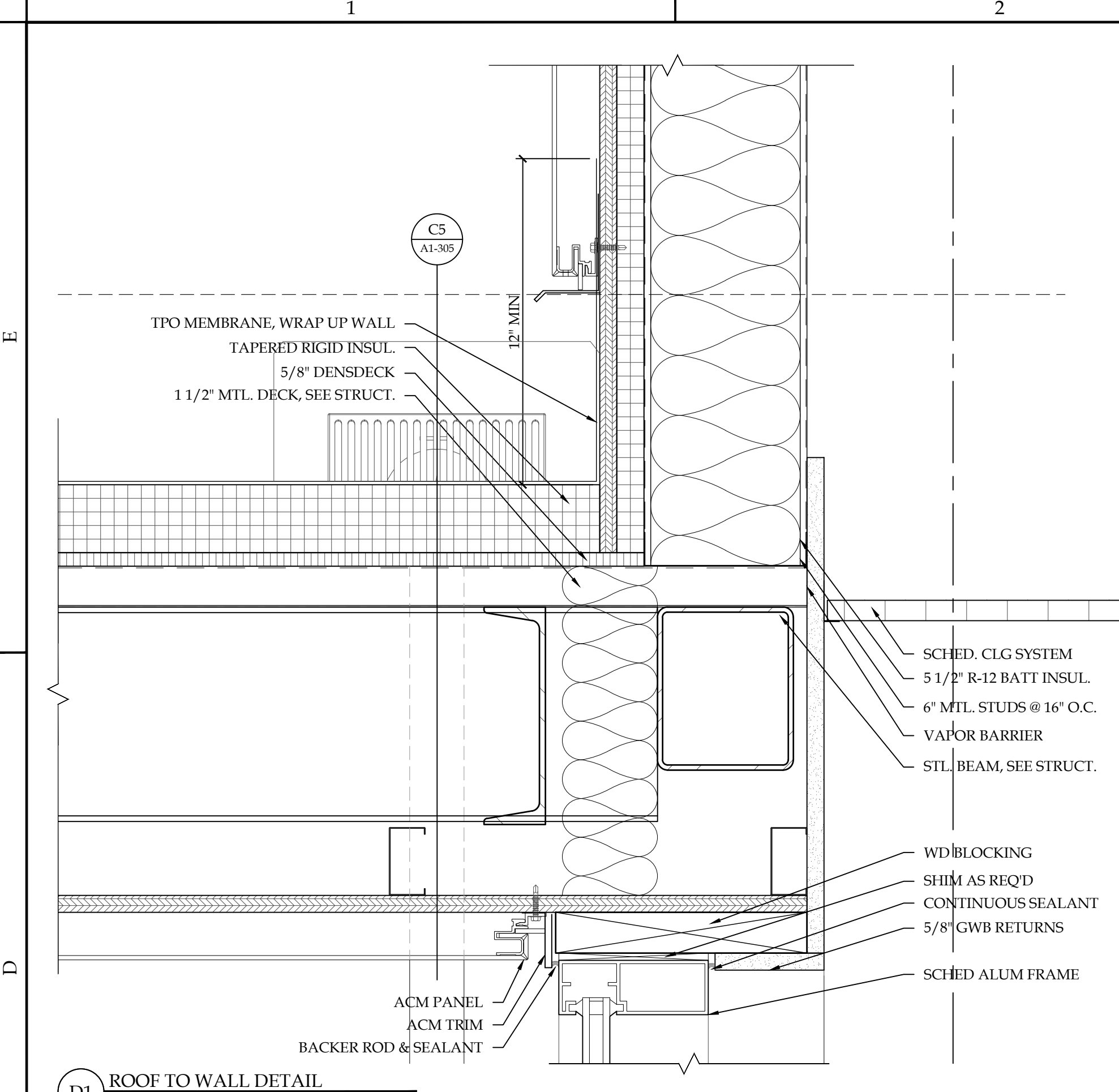

D1 ROOF TO WALL DETAIL  
7'-10"

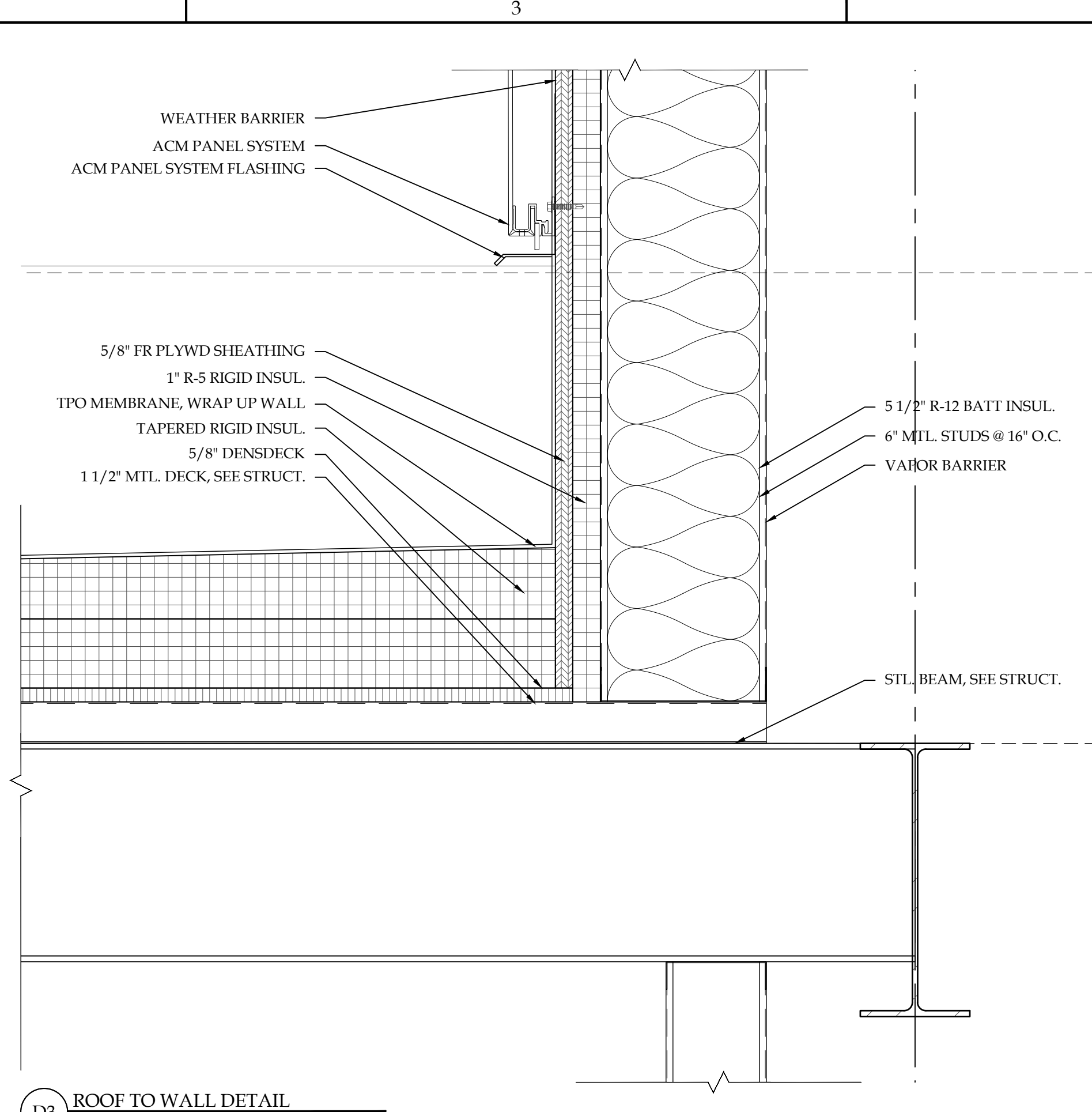

D3 ROOF TO WALL DETAIL  
7'-10"

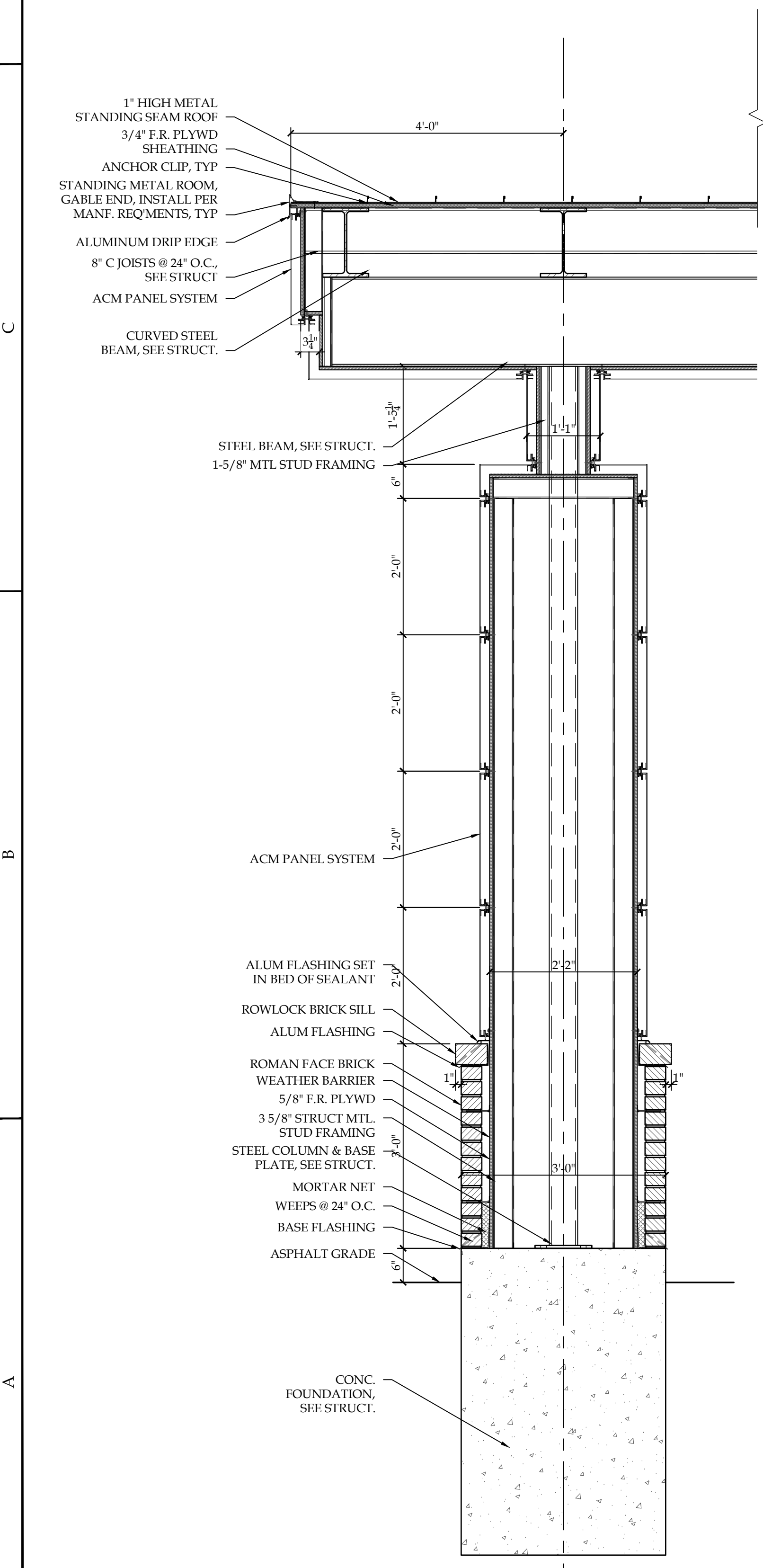

A1 PORTE COCHERE SECTION  
3/4" x 1'-0"

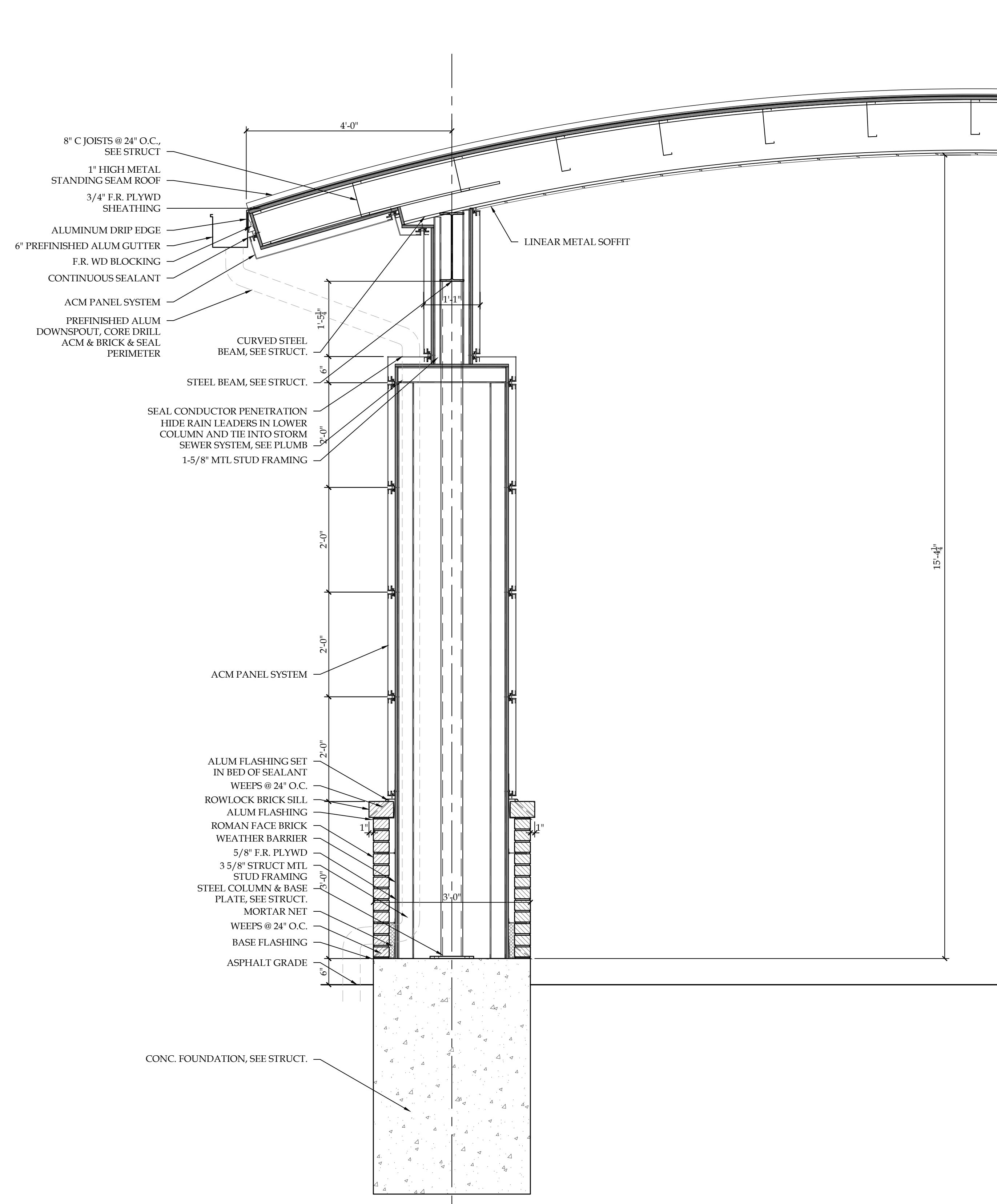

A2 PORTE COCHERE SECTION  
3/4" x 1'-0"

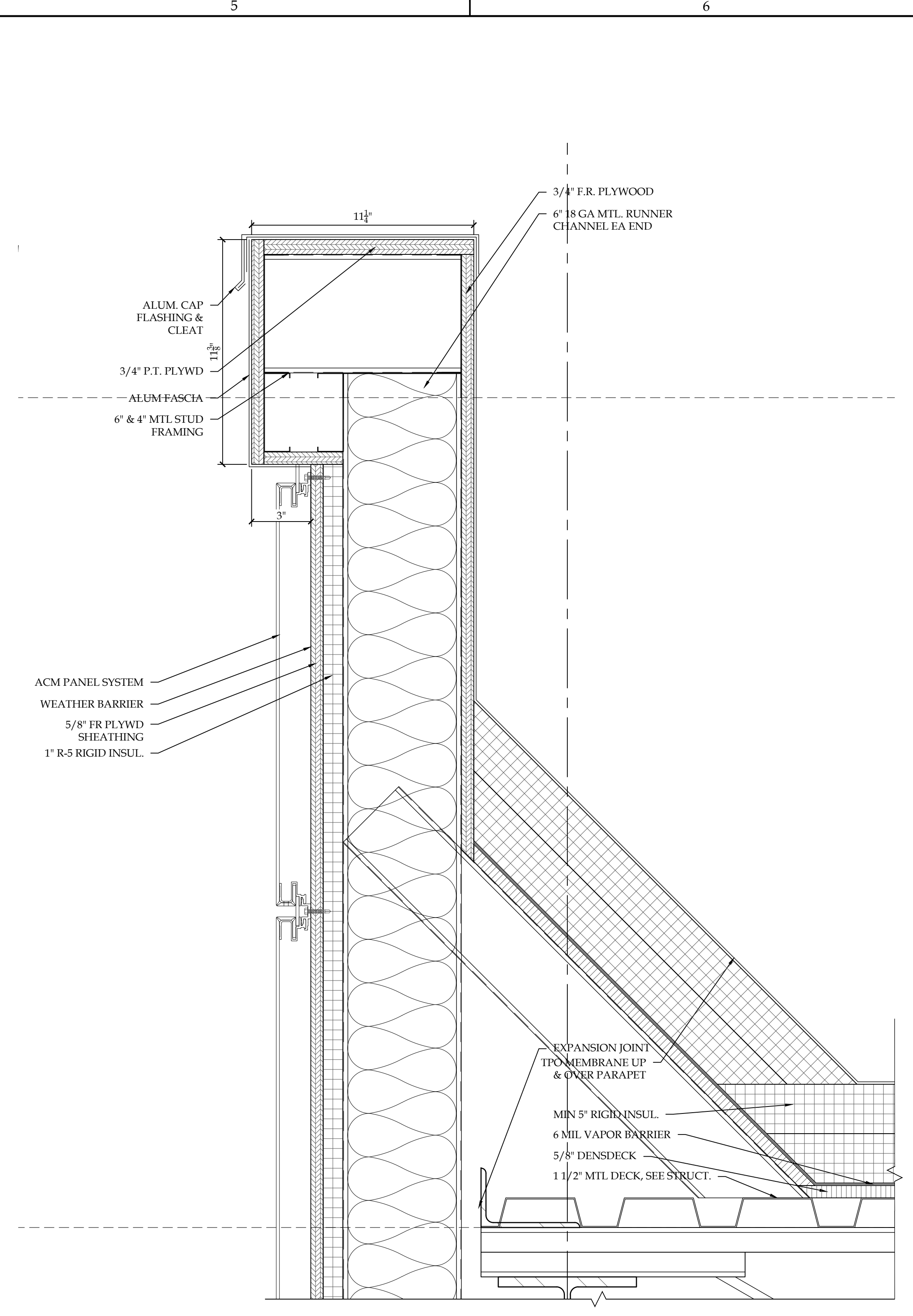

C5 PARAPET DETAIL  
7'-10"

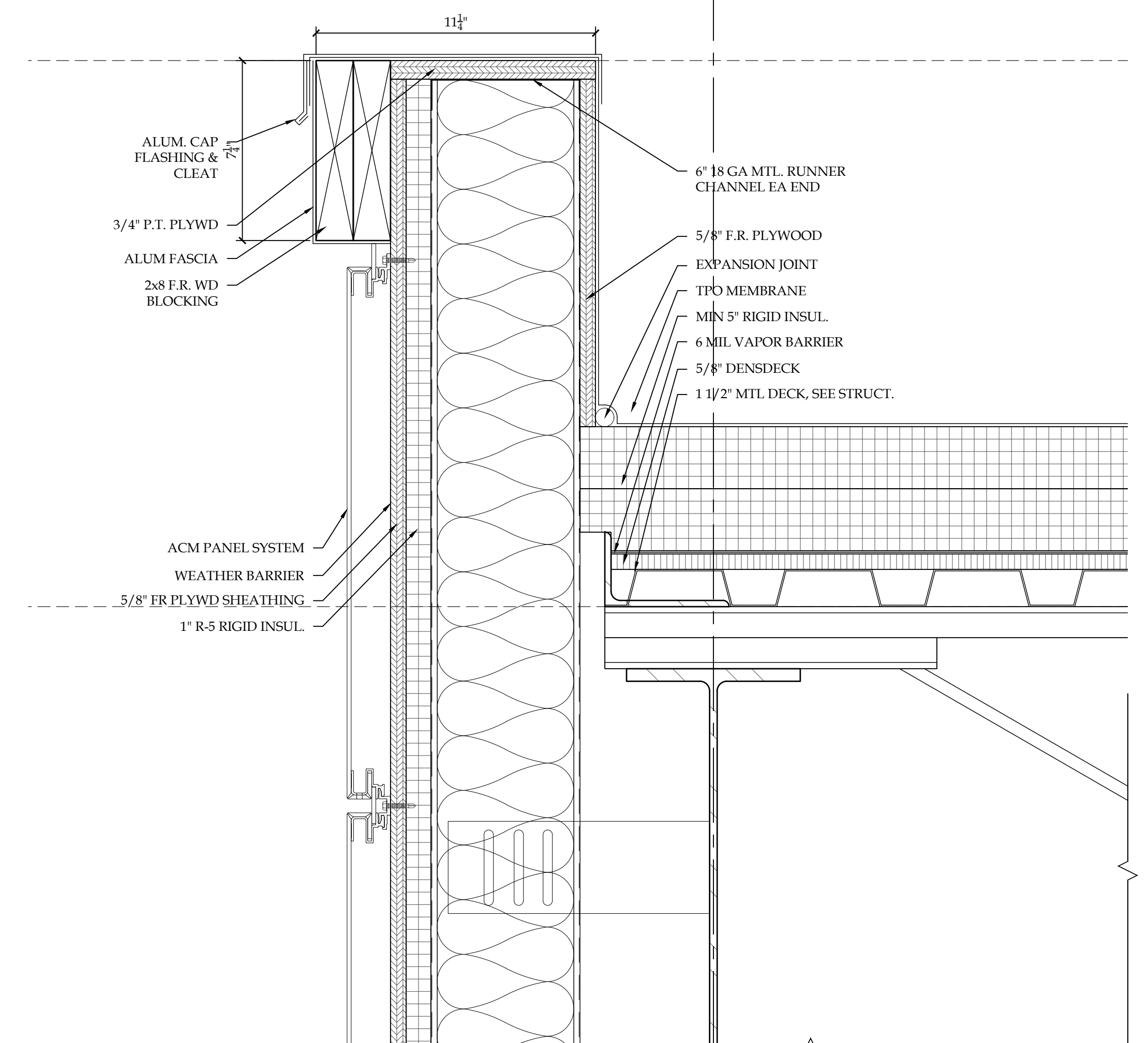

A5 PARAPET DETAIL  
7'-10"

**NOTICE**  
This document, the property of, prepared and issued by the architect, is submitted for the specific project named \_\_\_\_\_ and the recipient by accepting this document assumes custody and agrees that this document will not be copied or reproduced in part or in whole, and any special features peculiar to this design shall not be incorporated in any other project, unless prior agreement has been obtained in writing. These documents will be returned immediately upon completion of the project or upon the request of the architect.  
This document is the exclusive property of the architect, no rights to ownership are transferable, or shall be lost by the filing of this document with any and all public authorities for the purpose of compliance with Codes and or Ordinances, i.e. Building Permit, etc.

# Sterling 45 MOB - Shell

Sterling Business Park  
Windward Road  
Orchard Park, NY 14127

ISSUE:  
PERMIT SET 10-06-23

SA PROJECT TEAM: PRINCIPAL P.Silvestri  
PROJ. ARCH. \_\_\_\_\_ JOB CAPT. I.Somes  
INTERIORS A.Nagle \_\_\_\_\_ DRAFTER \_\_\_\_\_

SEAL:

## WALL SECTIONS & DETAILS



**SILVESTRI**  
ARCHITECTS + PC

1321 MILLERSPORT HWY PH. 716.691.0900  
AMHERST, NY 14221 FAX 716.691.4773

SA JOB #: 23020-01 DATE: 10-06-23

DRAWING #: A1-304

**NOTICE**  
 This document, the property of, prepared and issued by the architect, is submitted for the specific project and agrees that this document will not be copied or reproduced in part or in whole, and any special features peculiar to this design shall not be incorporated in any other project, unless prior agreement has been obtained in writing. These documents will be returned immediately upon completion of the project or upon the request of the architect.  
 This document is the exclusive property of the architect, no rights to ownership are transferable, or shall be lost by the filing of this document with any and all public authorities for the purpose of compliance with Codes and or Ordinances, i.e. Building Permit, etc.

# Sterling 45 MOB - Shell

Sterling Business Park  
 Windward Road  
 Orchard Park, NY 14127

ISSUE:  
 PERMIT SET 10-06-23  
 ADDENDUM 4 05-09-24

SA PROJECT TEAM: PRINCIPAL P.Silvestri  
 PROJ. ARCH. \_\_\_\_\_ JOB CAPT. J.Somes  
 INTERIORS A.Nagle \_\_\_\_\_ DRAFTER \_\_\_\_\_

SEAL:

## WALL SECTIONS & DETAILS



**SILVESTRI**  
 ARCHITECTS · PC

1321 MILLERSPORT HWY PH. 716.691.0900  
 AMHERST, NY 14221 FAX 716.691.4773

SA JOB #: 23020-01 DATE: 10-06-23

DRAWING #: A1-305

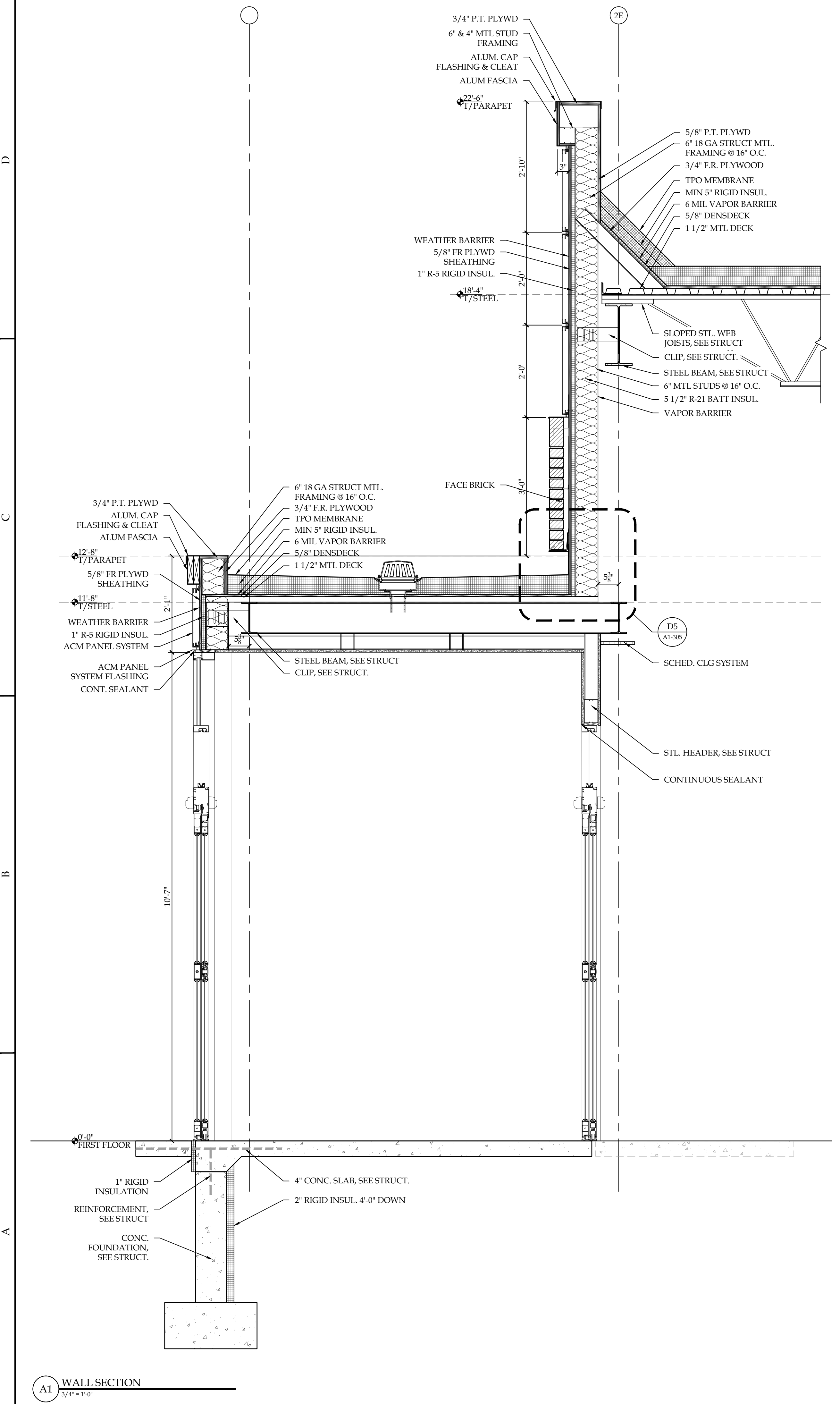
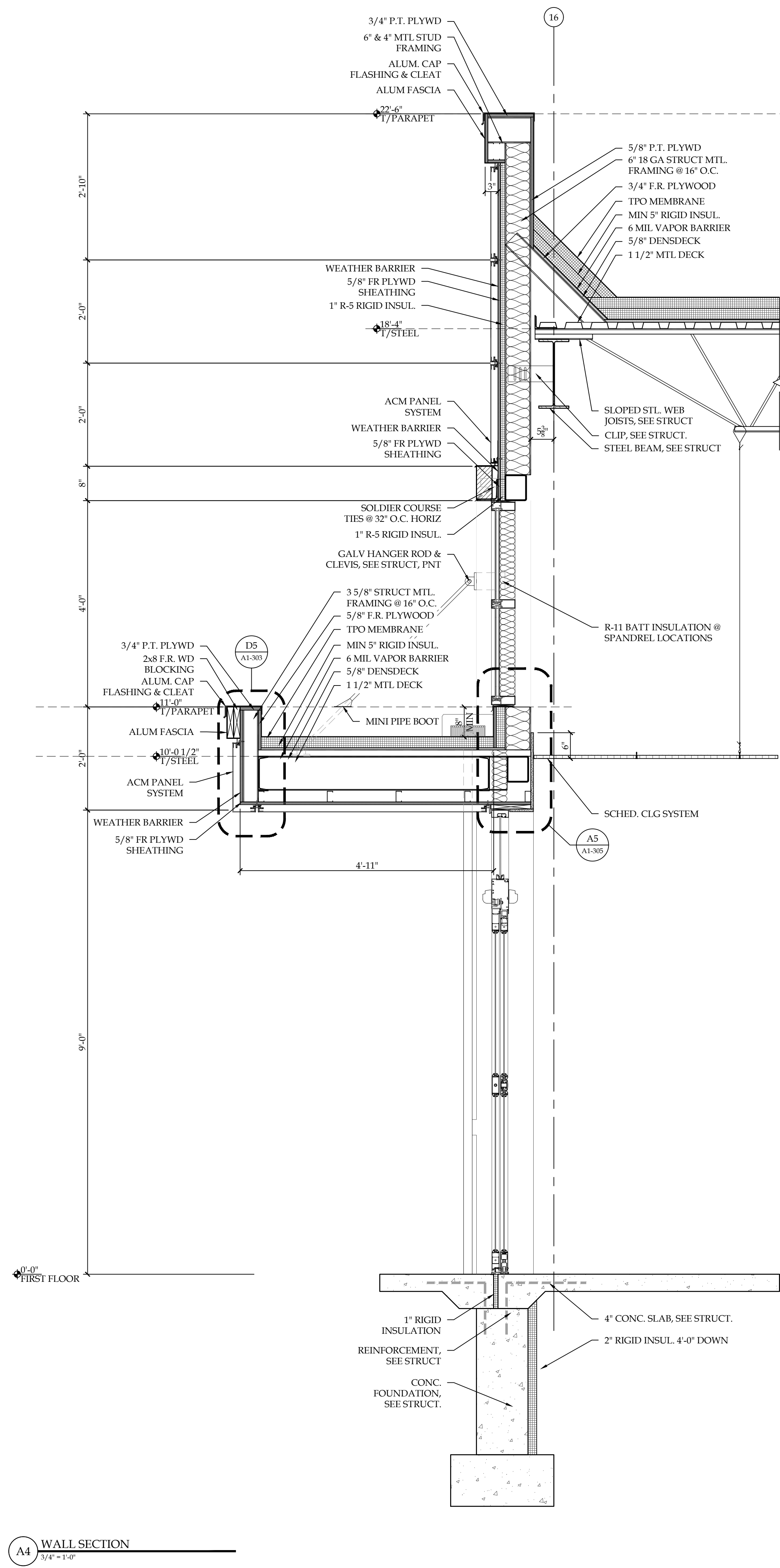
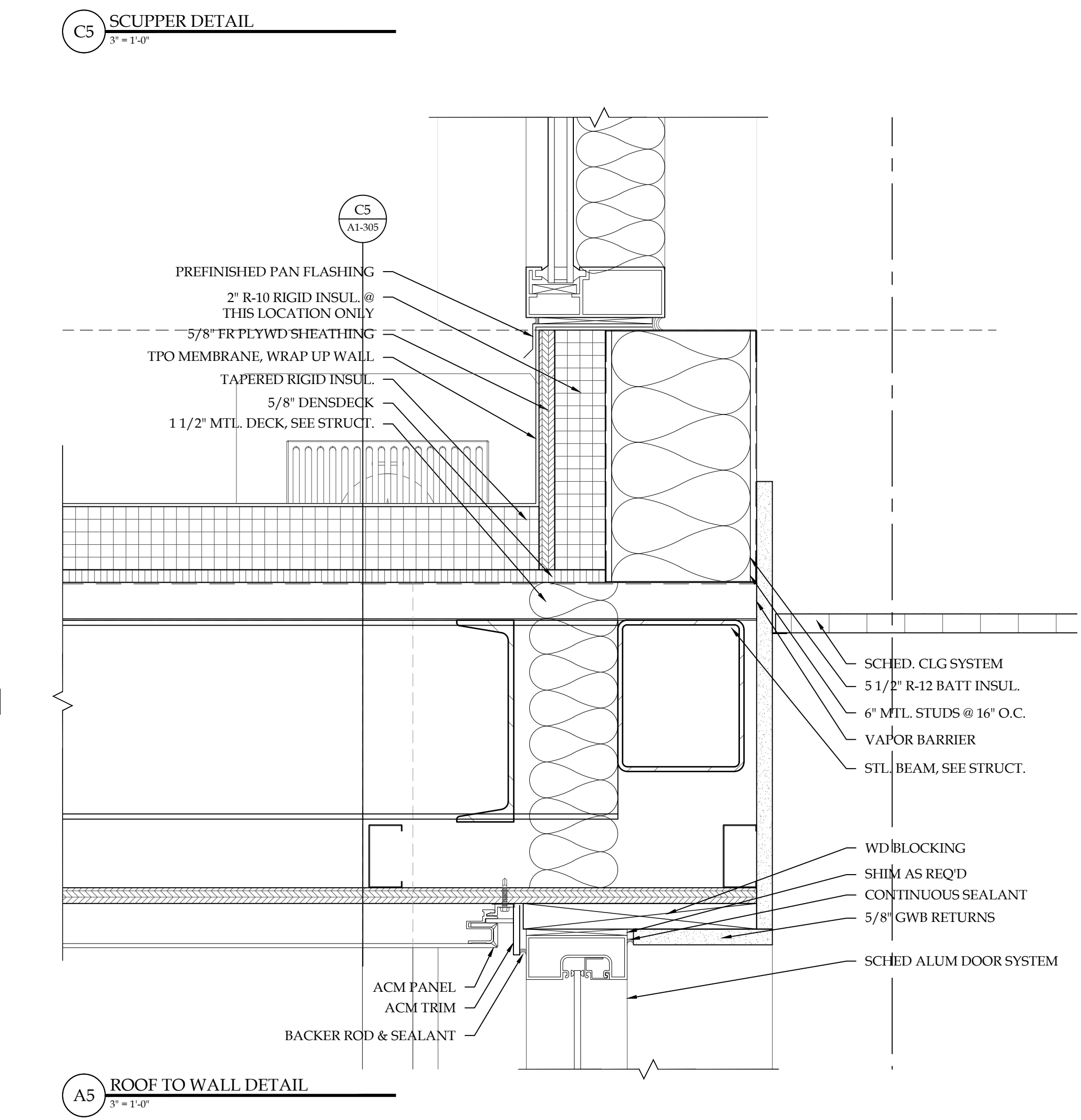
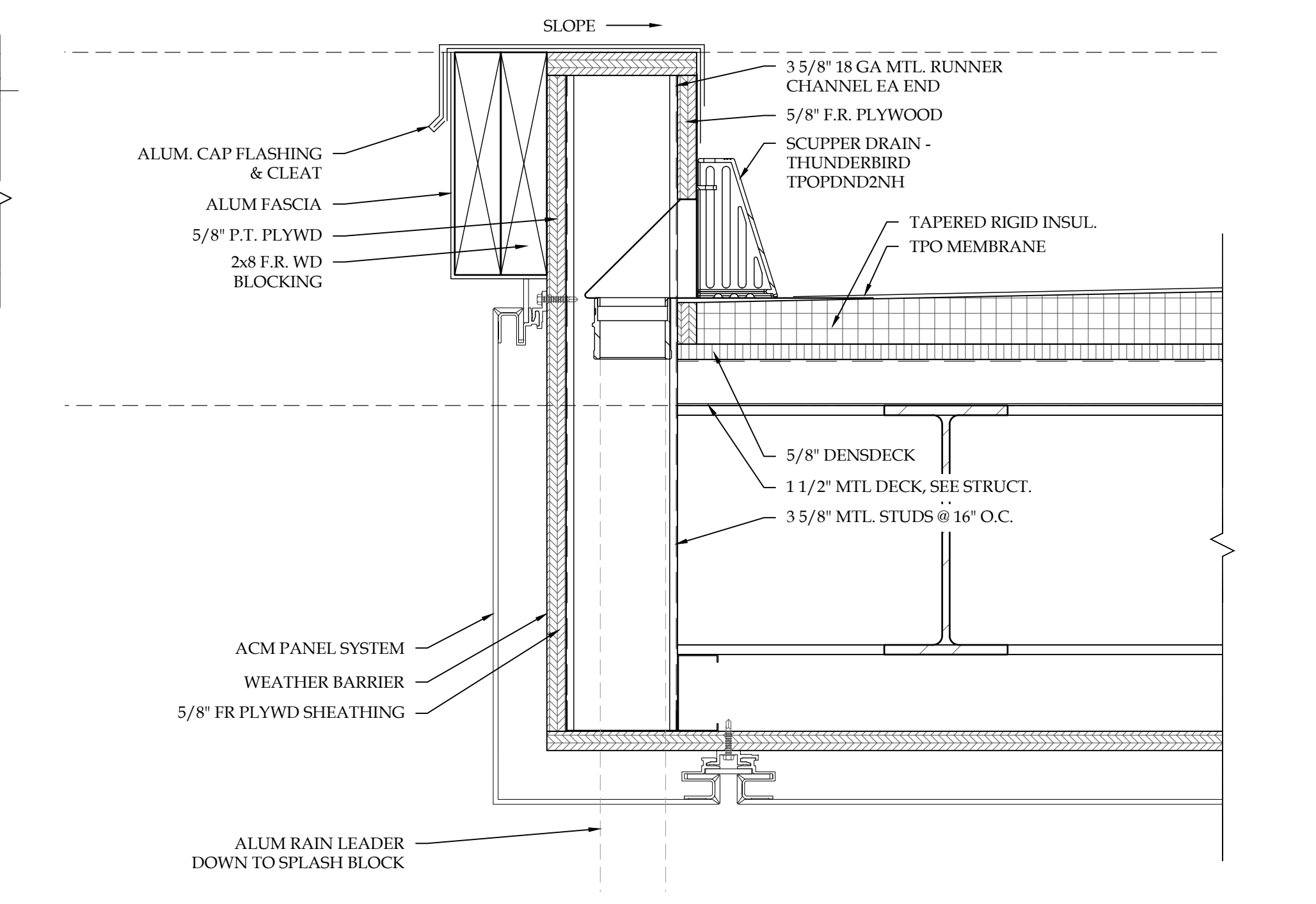
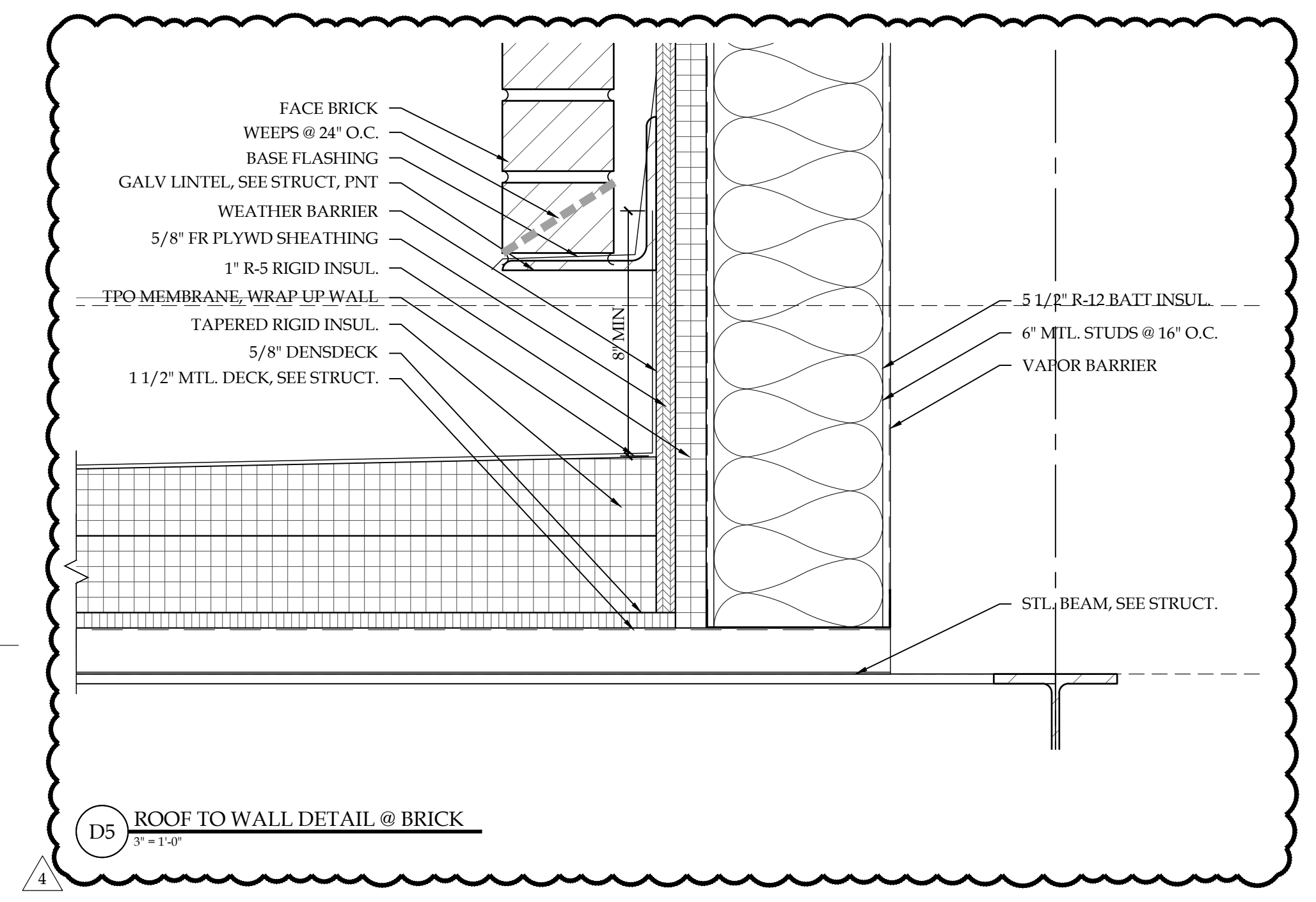

**NOTICE**  
 This document, the property of, prepared and issued by the architect, is submitted for the specific project named \_\_\_\_\_ and the recipient by accepting this document assumes custody and agrees that this document will not be copied or reproduced in part or in whole, and any special features peculiar to this design shall not be incorporated in any other project, unless prior agreement has been obtained in writing. These documents will be returned immediately upon completion of the project or upon the request of the architect.  
 This document is the exclusive property of the architect, no rights to ownership are transferable, or shall be lost by the filing of this document with any and all public authorities for the purpose of compliance with Codes and or Ordinances, i.e. Building Permit, etc.

# Sterling 45 MOB - Shell

Sterling Business Park  
 Windward Road  
 Orchard Park, NY 14127

ISSUE:  
 PERMIT SET 10-06-23

SA PROJECT TEAM: PRINCIPAL P.Silvestri  
 PROJ. ARCH. \_\_\_\_\_ JOB CAPT. J.Somers  
 INTERIORS A.Nagle \_\_\_\_\_ DRAFTER \_\_\_\_\_

SEAL:

## WALL SECTIONS & DETAILS



**SILVESTRI**  
 ARCHITECTS + PC  
 1321 MILLERSPORT HWY PH. 716.691.0900  
 AMHERST, NY 14221 FAX 716.691.4773

SA JOB #: 23020-01 DATE: 10-06-23

DRAWING #: A1-306

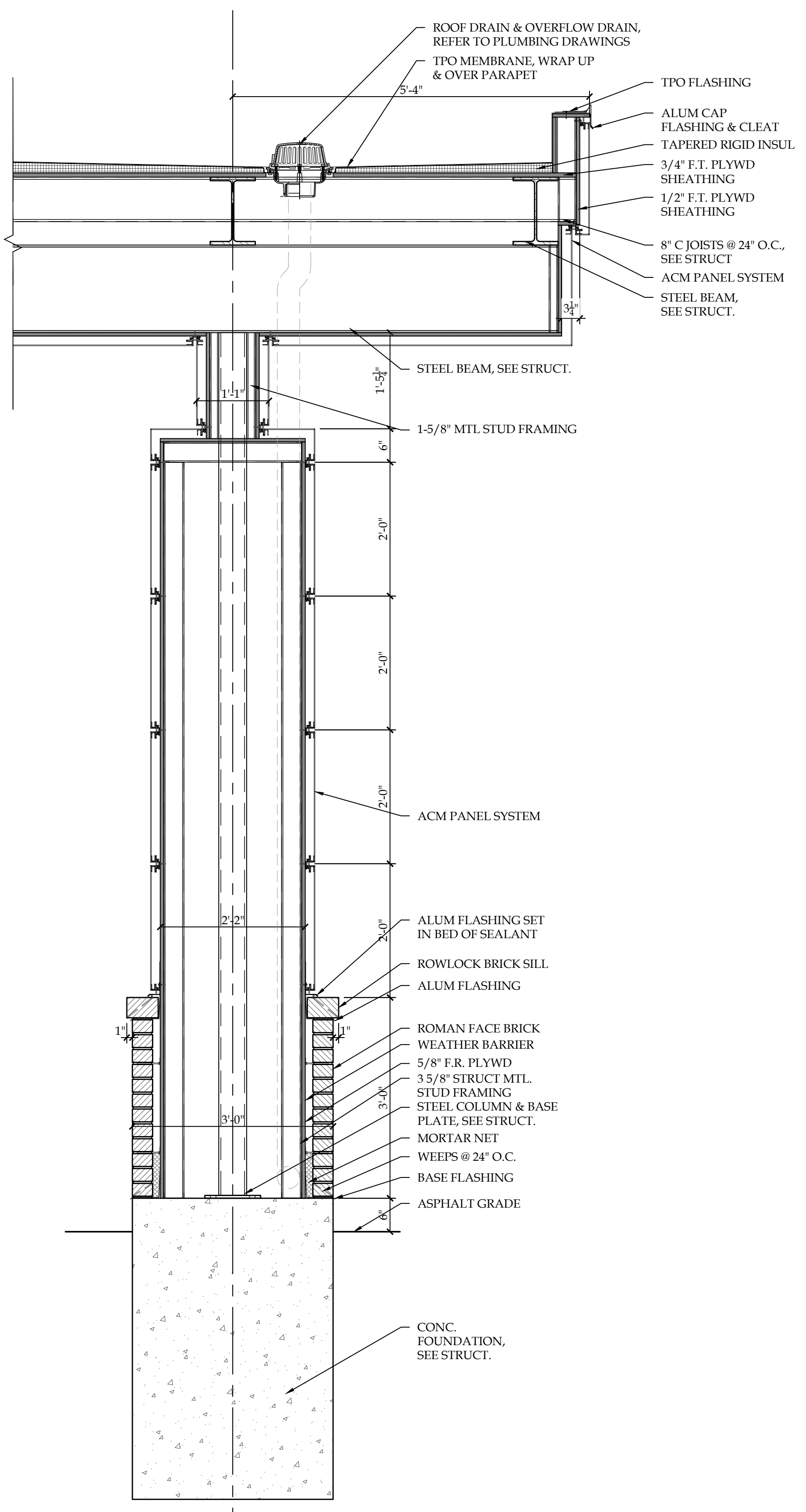
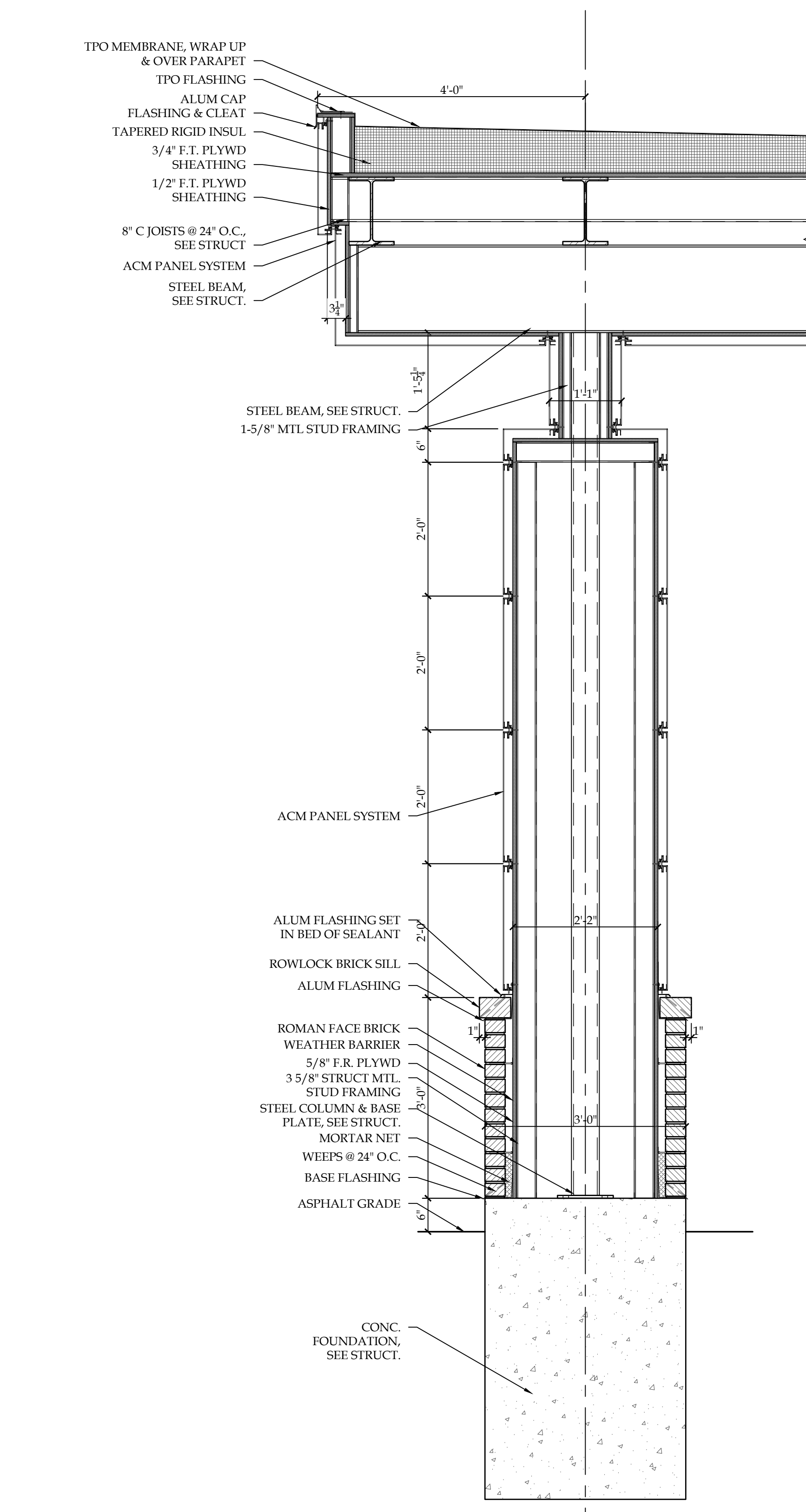
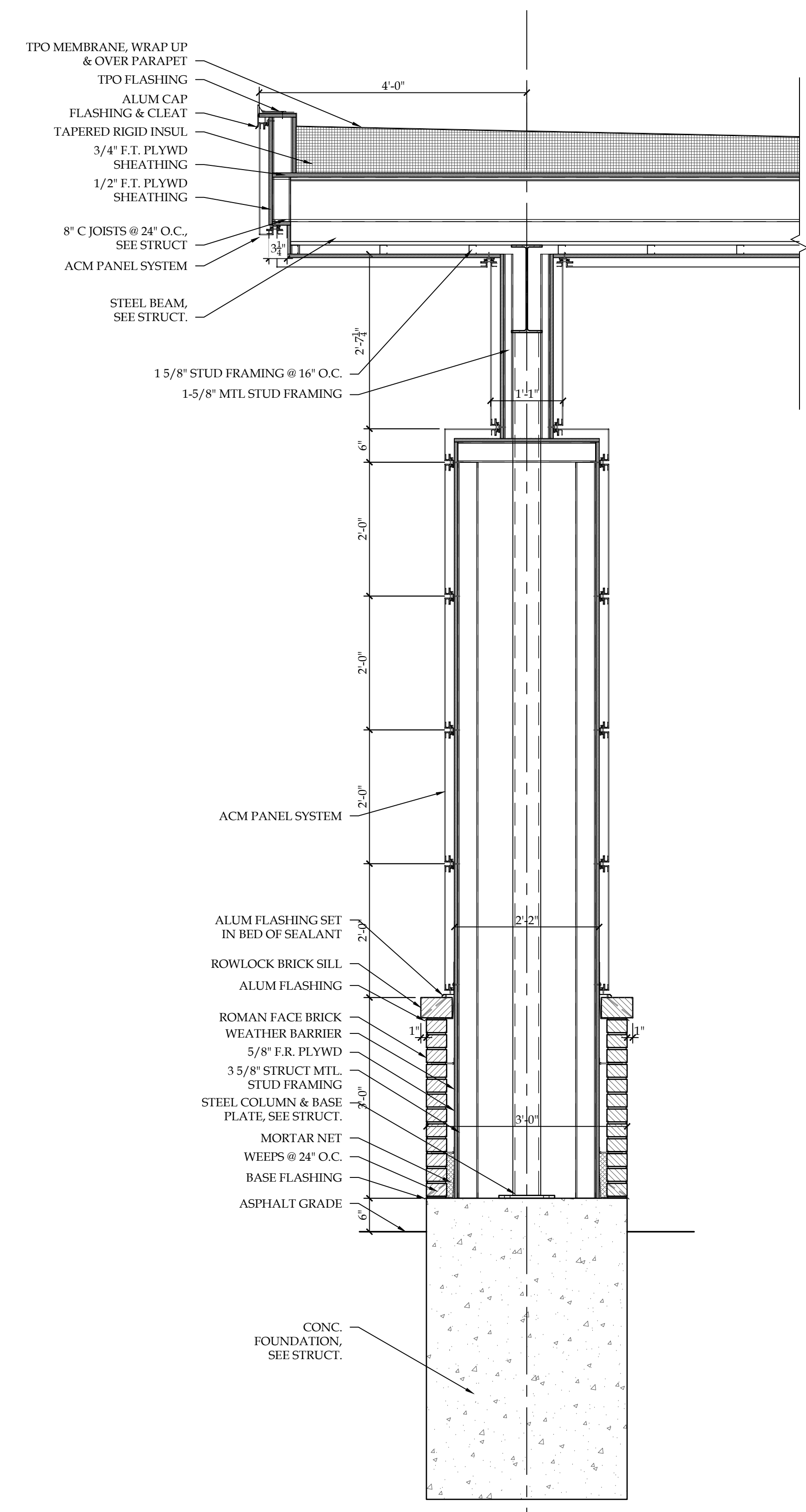

A1 NORTH PORTE COCHERE SECTION  
 3/4" = 1'-0"

A2 NORTH PORTE COCHERE SECTION  
 3/4" = 1'-0"

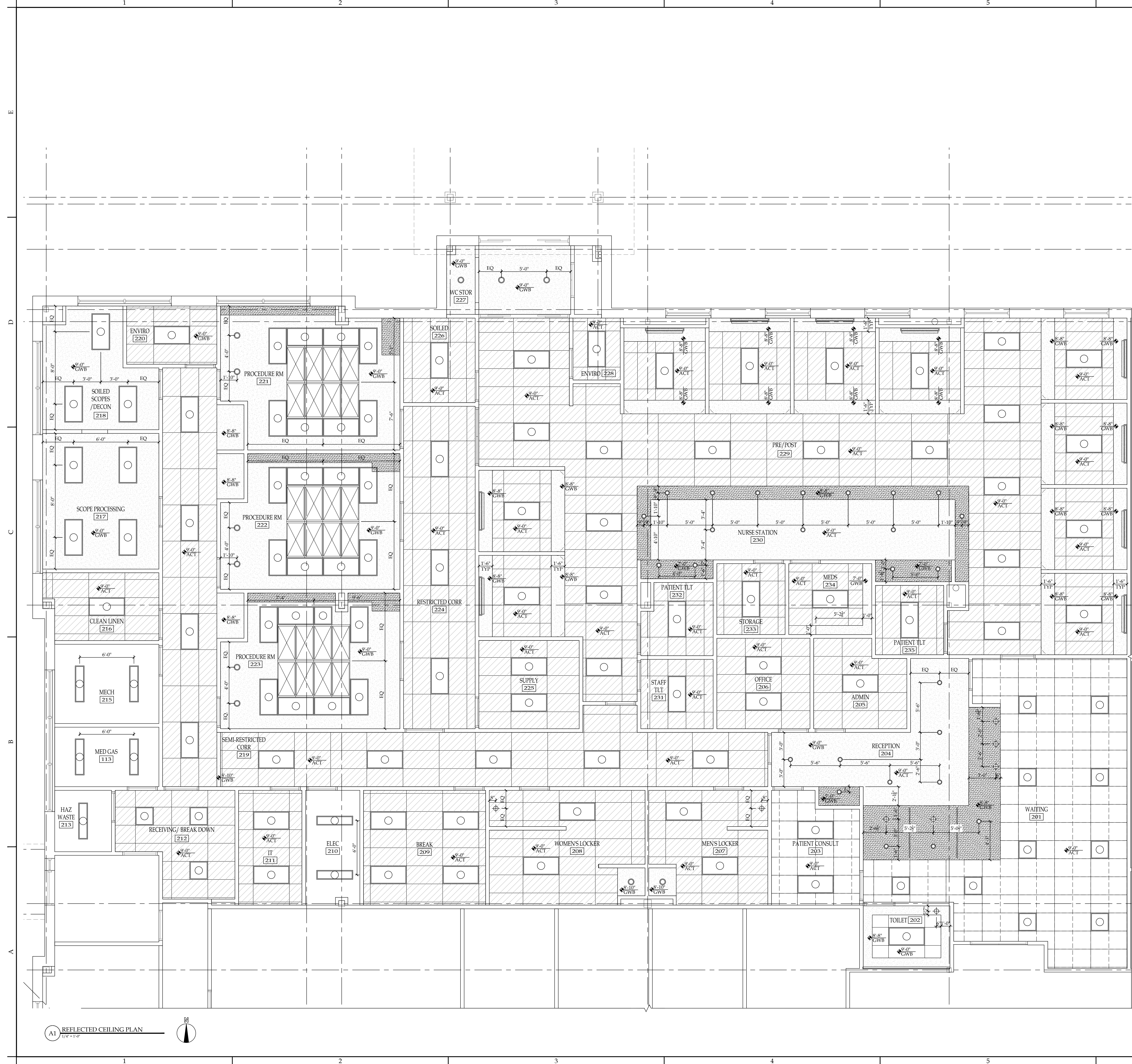

REFLECTED CEILING LEGEND	
SYMBOL	DESCRIPTION
	ACT-1 2'-0" X 4'-0" SUSPENDED "SECOND LOOK" ACOUSTIC CEILING, REGULAR EDGE
	GYPSUM WALL BOARD CEILING SYSTEM
	HEALTHZONE 2'-0" X 4'-0" SUSPENDED ACOUSTIC CEILING, REGULAR EDGE
	RECESSED CAN LIGHT FIXTURE
	DECORATIVE PENDANT LIGHT FIXTURE
	2 X 2 TROFFER LIGHT FIXTURE
	2 X 2 TROFFER LIGHT FIXTURE
	SUPPLY MECHANICAL DIFFUSER
	RETURN MECHANICAL DIFFUSER
	SPRINKLER

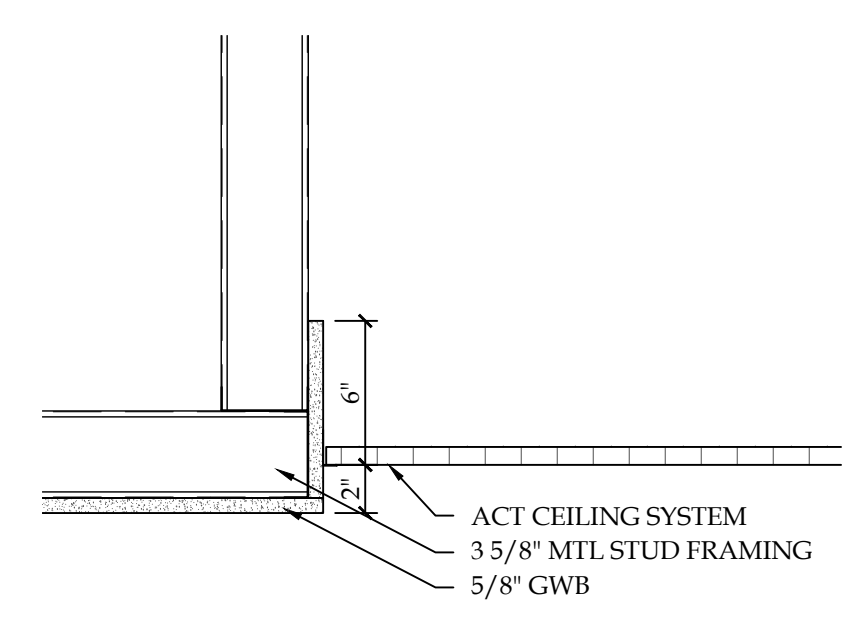

C6 SOFFIT DETAIL  
1/12" = 1'-0"

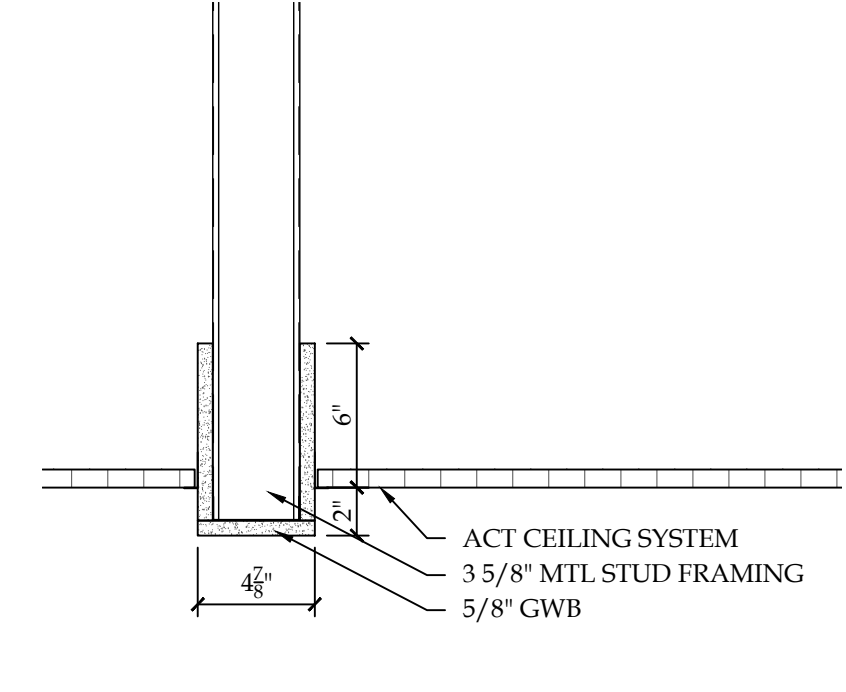

B6 SOFFIT DETAIL  
1/12" = 1'-0"

**NOTICE**  
This document, the property of, prepared and issued by the architect, is submitted for the specific project named \_\_\_\_\_ and the recipient by accepting this document assumes custody and agrees that this document will not be copied or reproduced in part or in whole, and any special features peculiar to this design shall not be incorporated in any other project, unless prior agreement has been obtained in writing. These documents will be returned immediately upon completion of the project or upon the request of the architect.  
This document is the exclusive property of the architect, no rights to ownership are transferable, or shall be lost by the filing of this document with any and all public authorities for the purpose of compliance with Codes and or Ordinances, i.e. Building Permit, etc.

# Sterling 45 MOB - GI Surgical Tenant Fit Out

Sterling Business Park  
Windward Road  
Orchard Park, NY 14127

ISSUE:

SA PROJECT TEAM: PRINCIPAL P.Silvestri  
INTERIORS A.Nagle JOB CAPT. J.Somes  
DRAFTER J.Somes

SEAL:

TITLE:

## REFLECTED CEILING PLAN



**SILVESTRI**  
ARCHITECTS + PC

1321 MILLERSPORT HWY PH. 716.691.0900  
AMHERST, NY 14221 FAX 716.691.4773

SA JOB #: 23020-02 DATE: 07-08-24

DRAWING #: A2-401

A1 REFLECTED CEILING PLAN  
1/4" = 1'-0"



**GENERAL NOTES**

- DO NOT SCALE DRAWINGS.
- CONSTRUCTION SHALL CONFORM TO ALL APPLICABLE BUILDING CODES OF NEW YORK STATE, OSHA STANDARDS, AND FIRE SAFETY CODE / RELEVANT SECTIONS OF THE N.E.P.A. & ANY LOCAL CODES BEING MORE RESTRICTIVE THAN THE MINIMUMS LISTED.
- CONSTRUCTION MEANS, METHODS, TECHNIQUES AND CRAFTSMANSHIP ARE THE RESPONSIBILITY OF THE GENERAL CONTRACTOR. G.C. SHALL VERIFY ALL DIMENSIONS AND CONDITIONS IN THE FIELD. CONTACT ARCHITECT IMMEDIATELY IF MAJOR DISCREPANCIES OCCUR BETWEEN DRAWINGS AND EXISTING CONDITIONS.
- THE CONTRACTOR IS REQUIRED TO INSPECT THE PROJECT SITE IN ORDER TO DETERMINE THE EXTENT OF THE REQUIRED WORK. THIS INSPECTION SHALL BE COMPLETED PRIOR TO THE SUBMISSION OF ANY PROPOSAL TO COMPLETE THIS PROJECT. INSPECTION TIMES SHALL BE COORDINATED WITH THE OWNER.
- THE CONTRACTOR IS RESPONSIBLE FOR COMPLIANCE WITH ALL INFORMATION ON THE DRAWINGS.
- THE CONTRACTOR'S ATTENTION IS DIRECTED TO THE FACT THAT DUE TO THE NATURE OF RECONSTRUCTION PROJECTS, THE EXACT EXTENT OF THE RECONSTRUCTION WORK CANNOT ALWAYS BE ACCURATELY DETERMINED PRIOR TO THE COMMENCEMENT OF THE WORK. THESE DOCUMENTS HAVE BEEN PREPARED BASED ON FIELD INSPECTIONS AND OTHER INFORMATION AVAILABLE AT THE TIME. ACTUAL FIELD CONDITIONS MAY REQUIRE MODIFICATION TO CONSTRUCTION DETAILS AND WORK QUANTITIES. THE CONTRACTOR SHALL BID & PERFORM THE WORK IN ACCORDANCE WITH THE FIELD CONDITIONS.
- ALL DIMENSIONS SHOWN FOR EXISTING STRUCTURES ARE BASED ON RECORD DRAWINGS AND FIELD MEASUREMENTS. THE CONTRACTOR IS ADVISED THAT SAID DRAWINGS MAY NOT ACCURATELY REFLECT AS BUILT CONDITIONS. ACCURATE FIELD MEASUREMENTS SHOULD BE MADE PRIOR TO ORDERING ANY PREFABRICATED MATERIALS. DISCREPANCIES SHALL BE REPORTED TO THE ARCHITECT AND SHALL BE REFLECTED ON THE CONTRACTOR'S SHOP DRAWINGS.
- THE DRAWINGS, SPECIFICATIONS AND OTHER DOCUMENTS FOR THIS PROJECT WILL BE COMPLETED TO THE SCOPE OF THE PROJECT IN COMPLIANCE WITH THE ARCHITECT AND DESIGN TEAM. ANY CHANGES TO THESE DRAWINGS, SPECIFICATIONS AND OTHER DOCUMENTS WILL ONLY BE DONE BY A CHANGE ORDER THAT IS APPROVED BY THE OWNER'S REPRESENTATIVE.
- CONSIDERATION WILL NOT BE GRANTED FOR ANY ALLEGED MISUNDERSTANDINGS AS TO THE AMOUNT AND / OR SCOPE OF WORK TO BE PERFORMED. TENDER OF PROPOSAL SHALL CONVEY FULL AGREEMENT TO THE ITEMS, AND CONDITIONS INDICATED IN THE CONSTRUCTION DOCUMENTS. SHOULD THE CONTRACTOR FIND DISCREPANCIES OR OMISSIONS IN THE CONSTRUCTION DOCUMENTS OR BE IN DOUBT AS TO THE INTENT THEREOF, THE CONTRACTOR SHALL IMMEDIATELY OBTAIN CLARIFICATION FROM THE ARCHITECT PRIOR TO SUBMITTING A PROPOSAL FOR THE WORK.
- ALL OWNER-SUPPLIED ITEMS WILL BE COORDINATED WITHIN THE GENERAL CONTRACTOR'S CONSTRUCTION SCHEDULES PRIOR TO COMMENCEMENT OF ANY WORK.
- THE CONTRACTOR SHALL COORDINATE HIS WORK AND SCHEDULE WITH THE OWNER FOR ALL BUILDING AND CONSTRUCTION SIGNAGE.
- THE CONTRACTOR IS RESPONSIBLE FOR THE COORDINATION OF HIS WORK AND SCHEDULE WITH WORK BEING PERFORMED BY OTHERS AND THE USER/OWNER OF THE BUILDING.
- ALL DIMENSIONS SHALL HAVE PRECEDENCE OVER SCALE. DO NOT SCALE DRAWINGS. ALL DIMENSIONS ARE TO FACE OF CONCRETE OR MASONRY, CENTERLINE OF COLUMNS AND BEAMS, AND FINISH TO FINISH, UNLESS OTHERWISE NOTED.
- THE STRUCTURAL, MECHANICAL, ELECTRICAL AND PLUMBING

- DRAWINGS ARE SUPPLEMENTARY TO THE ARCHITECTURAL DRAWINGS. IT SHALL BE THE RESPONSIBILITY OF THE CONTRACTOR TO CHECK WITH THE ARCHITECTURAL DRAWINGS BEFORE THE INSTALLATION OF STRUCTURAL, MECHANICAL, ELECTRICAL AND PLUMBING WORK. ANY DISCREPANCIES BETWEEN THE ARCHITECT'S AND ENGINEER'S DRAWINGS AND SPECIFICATIONS SHALL BE BROUGHT TO THE ARCHITECT'S ATTENTION FOR CLARIFICATION PRIOR TO PROCEEDING WITH SAID WORK.
- DETAILS MARKED "TYPICAL" SHALL APPLY IN ALL CASES UNLESS SPECIFICALLY INDICATED OTHERWISE.
- ALL SYMBOLS AND ABBREVIATIONS USED ON THE DRAWINGS ARE CONSIDERED TO BE CONSTRUCTION STANDARDS. IF THE CONTRACTOR HAS QUESTIONS REGARDING SOME, OR THEIR EXACT MEANING, THE ARCHITECT SHALL BE NOTIFIED FOR CLARIFICATION.
- CONTRACTOR SHALL VERIFY AND ESTABLISH THE LOCATIONS AND ELEVATIONS OF ALL UTILITIES WITHIN THE WORK AREA, AND SHALL COORDINATE WITH THE OWNER AND THE UTILITY COMPANIES PRIOR TO THE START OF THE PROJECT.
- THE CONTRACTOR SHALL PROVIDE ALL SHORING AND BRACING REQUIRED TO ADEQUATELY PROTECT PERSONAL AND ADJACENT PROPERTY AND TO INSURE SAFETY OF THE STRUCTURE THROUGHOUT THE CONSTRUCTION PERIOD.
- ALL CEILING HEIGHTS AS SHOWN ON DETAILS OR PLANS OR NOTES ARE FROM TOP OF CONCRETE DECK TO FINISH CEILING. USE OF THE TERM ABOVE FINISH FLOOR (A.F.F.) MEANS MEASURED FROM THE TOP OF CONCRETE DECK. CONTRACTOR SHALL ALLOW FOR AND COORDINATE WORK WITH FLOOR FINISH MATERIAL AND INSTALLATION METHOD.
- PROVIDE INDEPENDENT SUSPENSION FOR ALL LIGHT FIXTURES. SUSPENSION FOR CEILING AND LIGHT FIXTURES SHALL BE INDEPENDENT OF SUSPENSION FOR DUCT WORK.
- ALL EQUIPMENT AND MATERIALS INSTALLED IN THIS JOB SHALL BE NEW AND FREE OF ANY DEFECTS UNLESS OTHERWISE NOTED.
- CONTRACTORS SHALL RECORD ALL DEVIATIONS FROM THE DESIGN DOCUMENTS IN THE DRAWINGS, AND PROVIDE A COPY TO THE ARCHITECT UPON THE COMPLETION OF WORK.
- PROVIDE APPROVED SEPARATION BY MEANS OF COATINGS, GASKETS, OR OTHER EFFECTIVE MEANS TO PREVENT GALVANIC CORROSION BETWEEN ALL DISSIMILAR METALS.
- THE GENERAL CONTRACTOR SHALL BE RESPONSIBLE FOR REPAIRING ANY DAMAGE CAUSED BY THE CONSTRUCTION OPERATIONS OF THIS PROJECT TO ADJACENT PROPERTY, UTILITIES, PAVEMENT, LANDSCAPING, STRUCTURES OR IMPROVEMENTS OF ANY KIND. THE GENERAL CONTRACTOR SHALL REPAIR ALL SUCH DAMAGE D ITEMS TO THE CONDITION THEY WERE IN PRIOR TO COMMENCEMENT OF CONSTRUCTION ACTIVITIES OR BETTER.
- WHERE IT IS NECESSARY TO INSURE STABILITY, CONTRACTOR IS TO PROVIDE ADDITIONAL ANCHORING AND/OR BLOCKING IN STUD PARTITIONS OR BRACE PARTITIONS ABOVE CEILINGS.
- CONTRACTOR TO COORDINATE LOCATIONS OF FLOOR DRAINS WITH PLUMBING CONTRACTOR.
- AUTOMATIC SPRINKLER PROTECTION IS REQUIRED. AUTOMATIC SPRINKLER TO BE CONFIGURED AS REQUIRED FOR NEW CONSTRUCTION. CONTRACTOR TO PROVIDE LAYOUT AND THE MINIMUM REQUIREMENTS FOR THE DESIGN AND INSTALLATION OF AUTOMATIC FIRE SPRINKLER SYSTEM AND EXPOSURE PROTECTION SPRINKLER SYSTEMS, INCLUDING THE CHARACTER AND ADEQUACY OF WATER SUPPLIES AND THE SELECTION OF SPRINKLERS, PIPING, VALVES AND ALL OTHER MATERIALS AND ACCESSORIES IN ACCORDANCE WITH NFPA 13 AND LOCAL BUILDING CODES.
- ROOM IDENTIFICATION AND INTERIOR SIGNAGE BY CONTRACTOR. SIGNAGE SHALL COMPLY WITH ADA REQUIREMENTS.

- CONTRACTOR SHALL PROVIDE AND INSTALL FIRE EXTINGUISHERS PER CODE, INCLUDING NFPA 10, AND AS DIRECTED BY THE LOCAL FIRE DEPARTMENT THROUGHOUT BUILDING. FIRE EXTINGUISHER CONTRACTOR SHALL NOT PROJECT MORE THAN 4" BEYOND THE FACE OF THE WALL. RECESSED FIRE EXTINGUISHER CABINETS IN FIRE RATED WALLS SHALL HAVE THE SAME FIRE RATING AS THE WALL.
- DIMENSIONS TO EXTERIOR WALLS ARE ASSUMED FACE OF FOUNDATION WALL UNLESS OTHERWISE NOTED. ALL INTERIOR DIMENSIONS ARE TAKEN FROM FACE OF FINISHED WALL. ALL EXTERIOR DIMENSIONS ARE TO FACE OF SHEATHING, UNLESS OTHERWISE NOTED.
- BEFORE SUBMITTING BID, EXAMINE ALL DRAWINGS RELATED TO THE WORK. BECOME FULLY INFORMED AS TO THE EXTENT AND CHARACTER OF THE WORK OF ALL TRADES AND ITS RELATION TO THE WORK UNDER THE CONTRACT. NO CONSIDERATIONS WILL BE GIVEN FOR ALLEGED MISUNDERSTANDING OF THE MATERIALS TO BE FURNISHED OR THE WORK TO BE DONE.
- CONTRACTOR SHALL REVIEW AND SUBMIT SHOP DRAWINGS SUFFICIENTLY IN ADVANCE OF THE WORK TO ALLOW PROPER TIME FOR REVIEW. MATERIALS SHALL NOT BE FABRICATED OR DELIVERED TO THE SITE BEFORE THE SHOP DRAWINGS HAVE BEEN REVIEWED AND APPROVED BY THE OWNER'S REPRESENTATIVE.
- ALL SUBSTITUTE MANUFACTURERS EQUIPMENT, MATERIALS AND PRODUCTS SHALL BE APPROVED BY THE OWNER'S REPRESENTATIVE. THE CONTRACTOR IS RESPONSIBLE FOR ALL ASSOCIATED COSTS TO ANY AND ALL BUILDING COMPONENTS THAT ARE AFFECTED BY THE SUBSTITUTIONS. ADDITIONAL COSTS INCLUDE ANY REDESIGN THAT IS REQUIRED DUE TO THE SUBSTITUTION.
- DO NOT SCALE DRAWINGS. THE DIMENSIONS SHOWN ON THE PLANS MAY VARY FROM THE ACTUAL DIMENSIONS IN THE FIELD. IT IS, THEREFORE, IMPERATIVE THAT THE CONTRACTOR, PRIOR TO COMMENCEMENT OF WORK, TAKE EXACT MEASUREMENTS TO VERIFY ALL DIMENSIONS SHOWN ON THE PLANS AND SHOP DRAWINGS. ALL WORKING DRAWINGS PREPARED BY THE CONTRACTOR SHALL INCLUDE A STATEMENT CERTIFYING THAT THESE DRAWINGS HAVE BEEN PREPARED IN ACCORDANCE WITH THE FIELD MEASURED DIMENSIONS.
- THE CONTRACTOR SHALL NOTIFY THE ARCHITECT OF ANY AND ALL DISCREPANCIES BETWEEN FIELD CONDITIONS AND THE CONTRACT DOCUMENTS BEFORE PROCEEDING WITH THAT PORTION OF THE WORK. FAILURE TO NOTIFY THE ARCHITECT WILL NOT RELIEVE THE CONTRACTOR OF RESPONSIBILITY TO COMPLY WITH THE DOCUMENTS. THE CONTRACTOR SHALL CORRECT ANY AND ALL WORK ARISING FROM SUCH FAILURE AND COORDINATE DISCREPANCIES TO THE SATISFACTION OF THE ARCHITECT WITHOUT ADDITIONAL COST TO THE OWNER, RECOMMENDED BY MANUFACTURER.
- THE LOCATION FOR ALL ITEMS WHEN ON THE DRAWINGS OR CALLED FOR IN THE SPECIFICATIONS THAT ARE NOT DEFINITELY FIXED BY DIMENSIONS ARE DIAGRAMMATIC. THE EXACT LOCATIONS NECESSARY TO SECURE THE BEST CONDITIONS AND RESULTS MUST BE DETERMINED AT THE PROJECT AND SHALL HAVE THE APPROVAL OF THE OWNER'S REPRESENTATIVE BEFORE BEING INSTALLED. DO NOT SCALE DRAWINGS. THE CONTRACTOR SHALL FURNISH AND INSTALL, WITHOUT ADDITIONAL REMUNERATION, ANY COMPONENT NECESSARY TO COMPLETE THE SYSTEMS IN ACCORDANCE WITH THE BEST PRACTICE OF THE TRADE.
- DATA, COMMUNICATION, CABLE, AND SECURITY SYSTEMS ARE PROVIDED BY THE OWNER'S VENDORS. HOWEVER THE ELECTRICAL CONTRACTOR SHALL PROVIDE APPROPRIATE WALL BOXES, CONDUIT WITH PULL STRINGS, ETC. AS REQUIRED FOR ROUGH-IN CONDITIONS. ELECTRICAL CONTRACTOR IS RESPONSIBLE FOR COORDINATING THE LOCATION OF THESE ITEMS WITH THE OWNER'S VENDORS. ADA COMPLIANCE SHALL APPLY.
- MECHANICAL, ELECTRICAL, AND PLUMBING, ARE SCHEMATIC IN NATURE. THEREFORE, IT IS THE GENERAL CONTRACTOR'S RESPONSIBILITY TO COORDINATE THE ROUTING OF THESE TRADES,

- AS WELL AS, THE OWNER'S WORK TO ASSURE THAT THESE SYSTEMS DO NOT CONFLICT WITH THE ARCHITECTURAL AND STRUCTURAL ELEMENTS OF THE BUILDING. IF THE GENERAL CONTRACTOR ROUTE THESE ITEMS TO AVOID A CONFLICT, THEN THEY SHALL NOTIFY THE ARCHITECT PRIOR TO STARTING ANY RELATED WORK.
- CONTRACTOR TO PROTECT ALL NEW WORK DURING CONSTRUCTION AND REPLACE DAMAGED MATERIAL IN KIND.
- ALL GYPSUM WALL BOARD TO BE TAPED AND SANDED AT INTERSECTION OF CONSTRUCTION (NO. 'J' MOLD)
- PROVIDE CORNER BEAD AT ALL EXPOSED GYPSUM WALL BOARD CORNERS.
- DOOR OPENINGS SHALL BE LOCATED 4" FROM THE NEAREST FACE OF WALL IN MASONRY WALL CONSTRUCTION, UNLESS OTHERWISE NOTED.
- CONTRACTOR SHALL PROVIDE ALL MATERIALS, FABRICATION, LABOR AND SUPERVISION, ERECTION EQUIPMENT AND APPLIANCES REQUIRED TO INSTALL ALL EQUIPMENT SHOWN ON DRAWINGS AS INDICATED IN THE SPECIFICATIONS.
- THE TERM "PROVIDE" SHALL MEAN "FURNISH AND INSTALL, INCLUDING ALL LABOR, EQUIPMENT, MATERIALS AND PRODUCTS," UNLESS OTHERWISE NOTED.
- CONTRACTOR SHALL COORDINATE HER/HIS WORK WITH THE OWNER SO THAT THERE IS NO INTERFERENCE WITH OWNER'S PERSONAL OR WORK SCHEDULE.
- THE CONTRACTOR SHALL BE RESPONSIBLE FOR INITIATING, MAINTAINING AND SUPERVISING ALL SAFETY PRECAUTIONS AND PROGRAMS IN CONNECTION WITH THE PERFORMANCE OF THE CONTRACT.
- SAVE WORKING CONDITIONS ARE ALL SAFETY REQUIREMENTS ESTABLISHED BY JURISDICTIONAL AGENCIES AND/OR THE OWNER SHALL BE OBSERVED. WHERE CONFLICTS EXIST, THE MORE STRINGENT REQUIREMENTS SHALL APPLY. CARE MUST BE EXERCISED TO AVOID ENDANGERING PERSONNEL OR THE STRUCTURE.
- CONTRACTOR SHALL REMOVE ALL PROPERLY DISPOSE OF ALL DEBRIS FROM SITE AND LEAVE THE WORK AREA BROOM CLEAN ON A DAILY BASIS AND PROVIDE DUMPSTER SERVICE. PLACE DUMPSTERS AS DIRECTED BY THE "OWNER'S REPRESENTATIVE"
- CONTRACTOR SHALL FURNISH ALL SCAFFOLDING, HOISTING EQUIPMENT AND ANY OTHER EQUIPMENT THAT MAY BE REQUIRED TO PERFORM THE WORK INDICATED IN A SAFE AND ORDERLY MANNER.
- THE CONTRACTOR SHALL TAKE ALL NECESSARY PRECAUTIONS TO INSURE AGAINST DAMAGE TO EXISTING WORK TO REMAIN IN PLACE. ANY DAMAGE TO SUCH WORK SHALL BE REPAIRED OR REPLACED TO THE SATISFACTION OF THE OWNER AT NO ADDITIONAL COST.
- THE CONTRACTOR SHALL BE RESPONSIBLE FOR SECURING AND PAYING FOR ALL PERMITS AND APPROVALS NECESSARY FOR THE COMPLETION OF THE PROJECT.
- ALL NEW MATERIALS SHALL BE INSTALLED IN ACCORDANCE WITH THE MANUFACTURERS LATEST WRITTEN INSTRUCTIONS AND SPECIFICATIONS.
- THE CONTRACTOR SHALL COORDINATE ALL FINISHES AND COLOR SELECTIONS WITH THE OWNER.
- ALL FASTENERS INTO PRESSURE TREATED LUMBER ARE TO BE HOT DIPPED GALVANIZED OR STAINLESS STEEL AS RECOMMENDED BY MANUFACTURER.

**SPECIAL INSPECTION NOTES:**

- SPECIAL INSPECTIONS SHALL OCCUR PER BUILDING CODE OF NEW YORK STATE SECTION 106. THE OWNER SHALL EMPLOY ONE OR MORE SPECIAL INSPECTORS TO PROVIDE INSPECTIONS DURING CONSTRUCTION. THE SPECIAL INSPECTOR SHALL BE A QUALIFIED PERSON WHO SHALL DEMONSTRATE COMPETENCE TO THE SATISFACTION OF THE CODE ENFORCEMENT OFFICIAL. FOR INSPECTION OF THE PARTICULAR TYPE OF CONSTRUCTION OR OPERATION REQUIRING SPECIAL INSPECTION.
- THE QUALIFICATIONS OF ALL PERSONNEL PERFORMING SPECIAL INSPECTION ACTIVITIES ARE SUBJECT TO THE APPROVAL OF THE BUILDING OFFICIAL. THE CREDENTIALS OF ALL INSPECTORS AND TESTING TECHNICIANS SHALL BE PROVIDED IF REQUESTED.
- THE INSPECTION AND TESTING AGENT SHALL BE ENGAGED BY THE OWNER OR THE OWNER'S AGENT, AND NOT BY THE CONTRACTOR OR SUBCONTRACTOR WHOSE WORK IS TO BE INSPECTED OR TESTED. ANY CONFLICT OF INTEREST MUST BE DISCLOSED TO THE BUILDING OFFICIAL, PRIOR TO COMMENCING WORK.
- THE PERMIT APPLICANT SHALL SUBMIT A STATEMENT OF SPECIAL INSPECTIONS PREPARED BY THE REGISTERED DESIGN PROFESSIONAL IN RESPONSIBLE CHARGE IN ACCORDANCE WITH SECTION 106.4 AS A CONDITION FOR PERMIT ISSUANCE. THIS STATEMENT SHALL INCLUDE A COMPLETE LIST OF MATERIALS AND WORK REQUIRING SPECIAL INSPECTION BY THIS SECTION. THE INSPECTIONS TO BE PERFORMED AND A LIST OF THE INDIVIDUALS, APPROVED AGENCIES OR FIRMS INTENDED TO BE RETAINED FOR CONDUCTING SUCH INSPECTIONS.
- THE SPECIAL INSPECTOR SHALL KEEP RECORDS OF ALL INSPECTIONS AND SHALL FURNISH INSPECTION REPORTS TO THE BUILDING OFFICIAL, STRUCTURAL ENGINEER AND ARCHITECT OF RECORD. DISCOVERED DISCREPANCIES SHALL BE BROUGHT TO THE IMMEDIATE ATTENTION OF THE CONTRACTOR FOR CORRECTION. IF SUCH DISCREPANCIES ARE NOT CORRECTED, THE DISCREPANCIES SHALL BE BROUGHT TO THE ATTENTION OF THE BUILDING OFFICIAL, STRUCTURAL ENGINEER AND ARCHITECT OF RECORD. THE SPECIAL INSPECTION PROGRAM DOES NOT RELIEVE THE CONTRACTOR OF HIS OR HER RESPONSIBILITIES.

**GENERAL WALL NOTES**

- SEE SPECIFICATIONS FOR APPLICATIONS OF GYPSUM PRODUCTS, UNLESS NOTED ON DRAWINGS. REFER TO SPECIFICATIONS FOR SPECIAL APPLICATIONS, THICKNESS, AND TYPES, (I.E. MOLD & MOISTURE RESISTANCE, TILE BACKER BOARD, ETC.)
- REFER TO THE LATEST EDITION OF UNDERWRITERS LABORATORIES, INC. FIRE RESISTANCE DIRECTORY FOR ADDITIONAL REQUIREMENTS ON UL RATED ASSEMBLIES AS NOTED IN THE PARTITION DETAILS.
- USE ONLY PARTITIONS IDENTIFIED ON THE PLANS.
- STC = SOUND TRANSMISSION CLASS - REFER TO THE WALL SCHEDULE IN PLAN FOR WALLS THAT ARE SOUND RATED.
- ALL SEALANTS IN RATED WALL LOCATIONS REFERENCED IN THE WALL TYPE DETAILS SHALL BE SELECTED AND INSTALLED IN ACCORDANCE WITH THE MINIMUM REQUIREMENTS OF THE UNDERWRITERS LABORATORIES, INC FIRE RESISTANCE DIRECTORY. IN ADDITION TO FIRE RESISTANCE, WALL LOCATIONS CALLED OUT WITH REQUIRED ACOUSTICAL VALUE, AS NOTED IN WALL SCHEDULE, SHALL HAVE SEALANTS THAT MAINTAIN THE MINIMUM SOUNDS VALUE OF THE WALL PARTITION.

**SOUND INSULATION NOTES**

- ASSEMBLIES SHALL BE AIRTIGHT. HAIRLINE CRACKS AND HOLES ARE NOT ALLOWED.
- RECESSED WALL FIXTURES SUCH AS CABINETS, OUTLETS, AND OTHER ITEMS WHICH PENETRATE THE GYPSUM BOARD SURFACE SHOULD NOT BE LOCATED BACK TO BACK IN THE SAME STUD CAVITY.
- ANY OPENINGS CUT FOR ANY FIXTURES SHALL BE CAREFULLY CUT TO SIZE, PROPERLY FASTENED, INSULATED PER WALL ASSEMBLY AND PROPERLY CAULKED.
- THE ENTIRE PERIMETER OF A SOUND INSULATING ASSEMBLY MUST BE MADE AIRTIGHT TO PREVENT SOUND FROM "FLANKING".
- AN ACOUSTICAL SEALANT SHALL BE USED TO SEAL BETWEEN THE SOUND INSULATING ASSEMBLY AND ALL DISSIMILAR ASSEMBLIES AND BETWEEN THE ASSEMBLY AND SIMILAR SURFACES WHERE PERIMETER RELIEF IS REQUIRED. TAPING AND CAULKING OF GYPSUM BOARD WALL AND WALL-CEILING INTERSECTIONS PROVIDES AN ADEQUATE AIR SEAL AT THESE LOCATIONS.
- ALL SEALANTS IN RATED WALL LOCATIONS REFERENCED IN THE WALL TYPE DETAILS SHALL BE SELECTED AND INSTALLED IN ACCORDANCE WITH THE MINIMUM REQUIREMENTS OF THE UNDERWRITERS LABORATORIES, INC FIRE RESISTANCE DIRECTORY. IN ADDITION TO FIRE RESISTANCE, WALL LOCATIONS CALLED OUT WITH REQUIRED ACOUSTICAL VALUE, AS NOTED IN WALL SCHEDULE, SHALL HAVE SEALANTS THAT MAINTAIN THE MINIMUM SOUNDS VALUE OF THE WALL PARTITION.
- ASTM RECOMMENDED PRACTICES E-497 SHALL BE FOLLOWED FOR GOOD SOUND CONTROL. ALSO CONSULT THE MANUFACTURER OF THE GYPSUM BOARD FOR ANY SPECIAL RECOMMENDATIONS RELATING TO THEIR SYSTEM.

**NOTICE**

This document, the property of, prepared and issued by the architect, is submitted for the specific project namely \_\_\_\_\_ and the recipient by accepting this document assumes custody and agrees that this document will not be copied or reproduced in part or in whole, and any special features peculiar to this design shall not be incorporated in any other project, unless prior agreement has been obtained in writing. These documents will be returned immediately upon completion of the project or upon the request of the architect.

This document is the exclusive property of the architect, no rights to ownership are transferable, or shall be lost by the filing of this document with any and all public authorities for the purpose of compliance with Codes and or Ordinances, i.e. Building Permit, etc.

**Sterling 45 MOB - GI Surgical Tenant Fit Out**

Sterling Business Park  
Windward Road  
Orchard Park, NY 14127

ISSUE:

SA PROJECT TEAM: PRINCIPAL E.Silvestri  
INTERIORS A.Nagle JOB CAPT. J.Somes  
DRAFTER J.Somes

SCALE:

TITLE:

**GENERAL NOTES & PARTITION TYPES**



**SILVESTRI ARCHITECTS PC**  
1321 MILLERSPORT HWY PH. 716.691.0900  
AMHERST, NY 14221 FAX 716.691.4773

SA JOB #: **23020-02** DATE: **07-08-24**

DRAWING #: **A2-501**

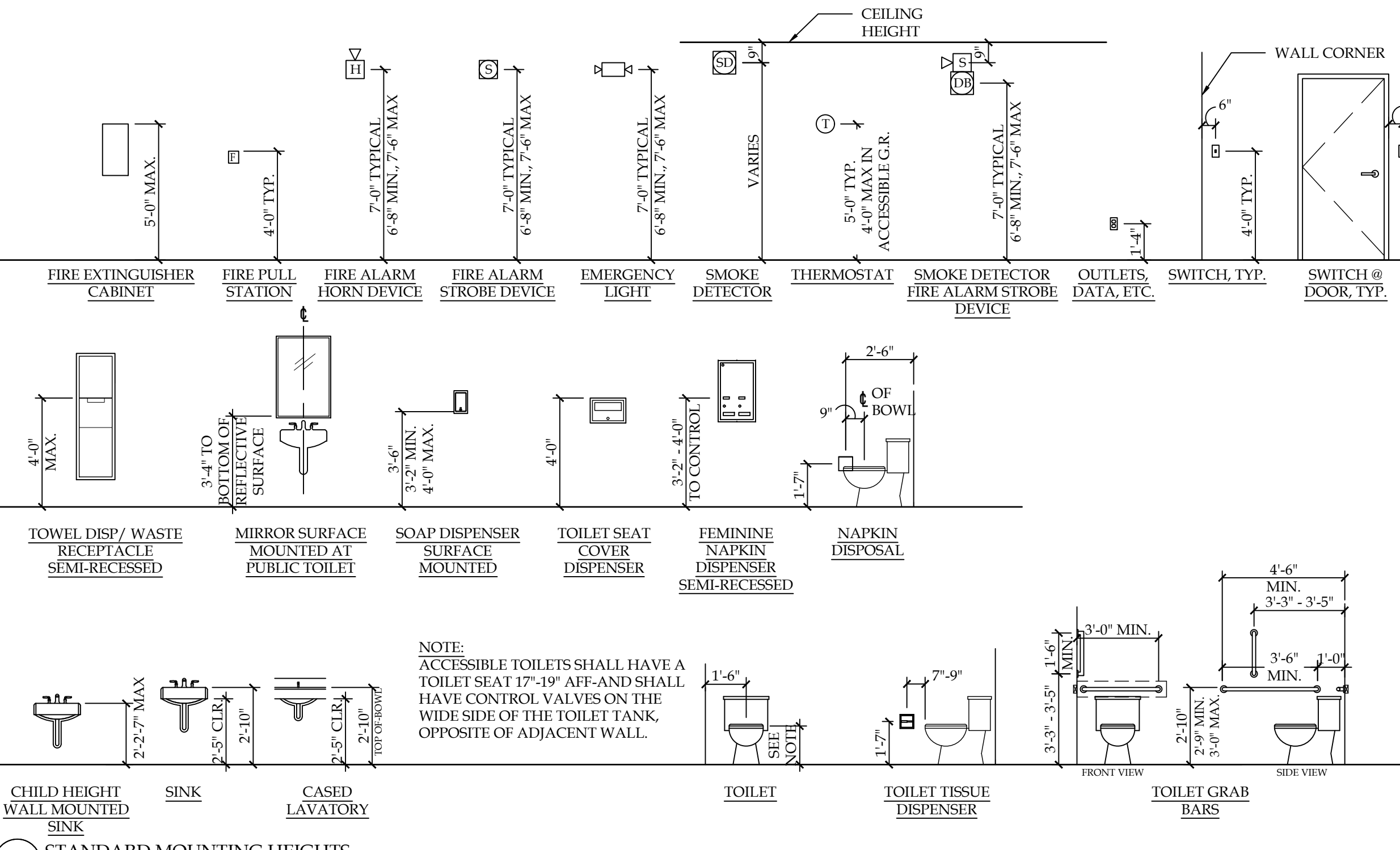

**STANDARD MOUNTING HEIGHTS**  
SCALE: 1/4" = 1'-0"

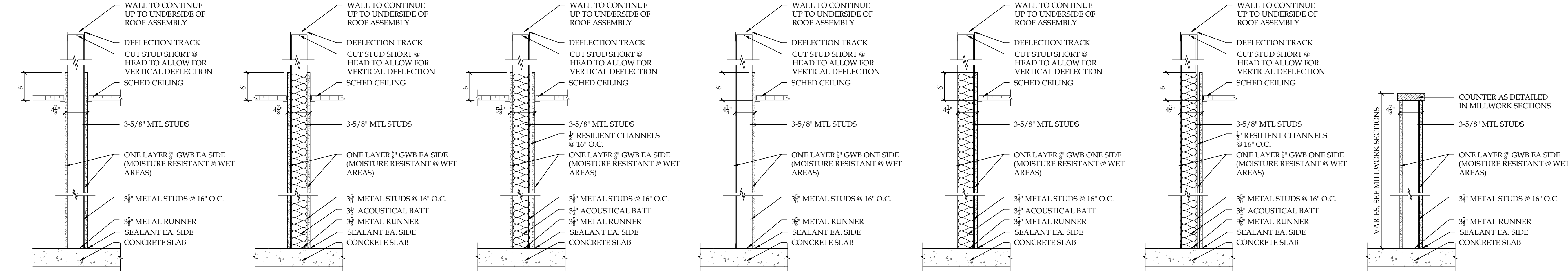

**1** 3-5/8" MTL STUD WALL  
**2** 3-5/8" MTL STUD ACOUSTICAL WALL  
**3** 3-5/8" MTL STUD ACOUSTICAL WALL  
**4** 3-5/8" MTL STUD CHASE WALL  
**5** 3-5/8" MTL STUD ACOUSTICAL CHASE WALL  
**6** 3-5/8" MTL STUD ACOUSTICAL CHASE WALL  
**7** 3-5/8" MTL STUD PARTIAL HEIGHT WALL

**A1 PARTITION TYPES**

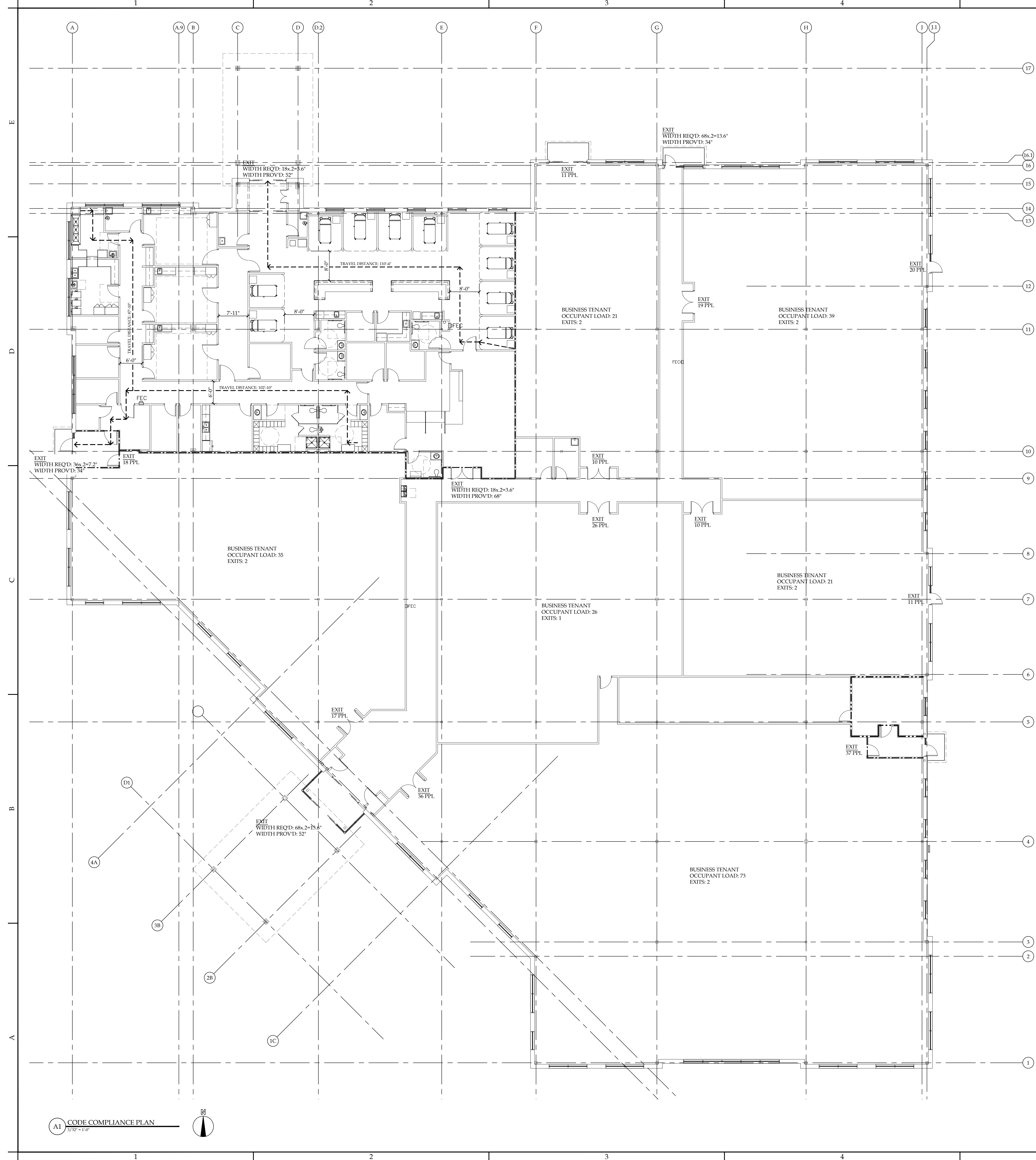

**KEY:**

- 1 HR FIRE BARRIER
- SMOKE BARRIER
- EXIT DISTANCE
- ⊗ EXIT SIGN

**APPLICABLE CODES & GUIDELINES:**

- 2020 BCNYS
- 2020 NYSECC
- 2020 PCNYS
- 2020 FGCNYS
- 2020 MCNYS
- 2012 NFPA
- 2018 NFPA 101
- 2018 GUIDELINES FOR DESIGN AND CONSTRUCTION OF HEALTH CARE FACILITIES (FGI)
- 2010 ADA STANDARDS FOR ACCESSIBLE DESIGN (ADAAG) INCLUDING ALL REFORMED STANDARDS THEREIN

**BUILDING INFORMATION:**

OCCUPANCY CLASSIFICATION:  
NEW AMBULATORY HEALTH CARE OCCUPANCIES (NFPA 101 CH. 20)  
CONSTRUCTION TYPE: IIB  
FULLY SPRINKLERED NFPA 13  
TOTAL GROSS TENANT AREA: 8,099 SF  
OCCUPANCY:  
(b) BUSINESS

OCCUPANT LOAD:  
8,099 SF / 150 = 54 PEOPLE

EXIT WIDTH REQUIRED: 54 X 2' = 6.8"  
EXIT WIDTH PROVIDED: 21.2"  
MAXIMUM TRAVEL DISTANCE ALLOWED: 200' MAX PERMITTED  
MAXIMUM SMOKE COMPARTMENT AREA: 22,500 SF  
DEAD END CORRIDOR: MAX 50' PERMITTED  
CORRIDOR WIDTH: MIN 44' PERMITTED  
NUMBER OF EXITS REQUIRED: 2  
NUMBER OF EXITS PROVIDED: 5

**PLUMBING FIXTURES**

REQD	PROV
T L DF MOP T L DF MOP	T L DF MOP
PPL: 54	3 2 1 1 8 6 1COMMON 2

**NOTICE**  
This document, the property of, prepared and issued by the architect, is submitted for the specific project named \_\_\_\_\_ and the recipient by accepting this document assumes custody and agrees that this document will not be copied or reproduced in part or in whole, and any special features peculiar to this design shall not be incorporated in any other project, unless prior agreement has been obtained in writing. These documents will be returned immediately upon completion of the project or upon the request of the architect.  
This document is the exclusive property of the architect, no rights to ownership are transferable, or shall be lost by the filing of this document with any and all public authorities for the purpose of compliance with Codes and or Ordinances, i.e. Building Permit, etc.

# Sterling 45 MOB - GI Surgical Tenant Fit Out

Sterling Business Park  
Windward Road  
Orchard Park, NY 14127

ISSUE:

SA PROJECT TEAM: PRINCIPAL P.Silvestri  
INTERIORS A.Nagle JOB CAPT. J.Somes  
DRAFTER J.Somes

SEAL:

## LIFE SAFETY PLAN



**SILVESTRI ARCHITECTS + PC**  
1321 MILLERSPORT HWY PH. 716.691.0900  
AMHERST, NY 14221 FAX 716.691.4773

SA JOB #: 23020-02 DATE: 07-08-24

DRAWING #: LSC2-101

All Rights Reserved. Reuse of these documents without the expressed written permission of CARMINA WOOD DESIGN is prohibited. Warning it is a violation of article 45 of the New York State Education Law to alter this drawing. If altered such R.A., P.E. or L.L.S. shall affix his or her seal, signature, the date the notation altered by and a specific description of the alteration.

© CARMINA WOOD DESIGN

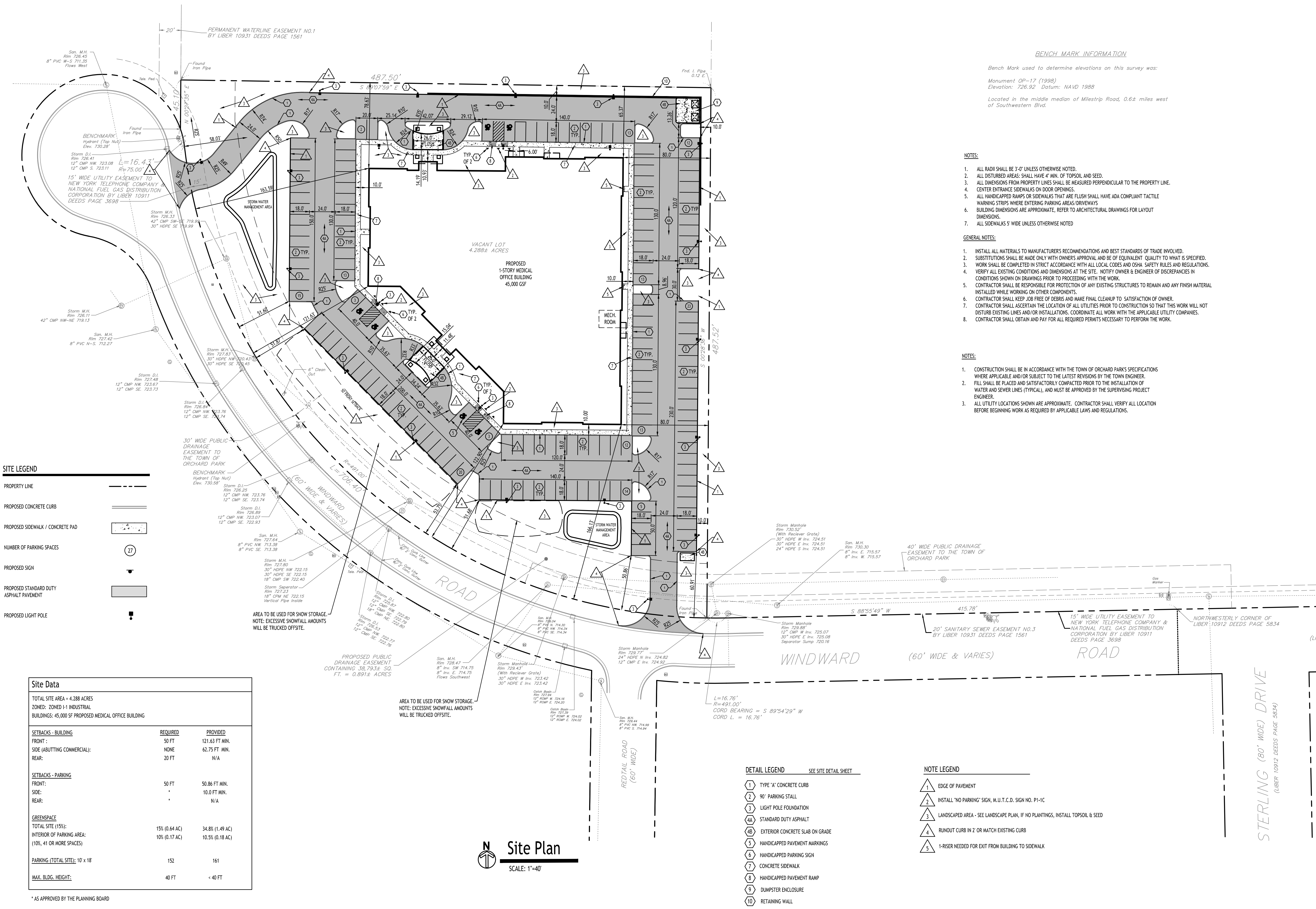

**BENCHMARK INFORMATION**  
 Bench Mark used to determine elevations on this survey was:  
 Monument OP-17 (1998)  
 Elevation: 726.92 Datum: NAVD 1988  
 Located in the middle median of Milestrip Road, 0.6± miles west of Southwestern Blvd.

- NOTES:**
- ALL RADI SHALL BE 3'-0" UNLESS OTHERWISE NOTED.
  - ALL DISTURBED AREAS SHALL HAVE 4" MIN. OF TOPSOIL AND SEED.
  - ALL DIMENSIONS FROM PROPERTY LINES SHALL BE MEASURED PERPENDICULAR TO THE PROPERTY LINE.
  - CENTER ENTRANCE SIDEWALKS ON DOOR OPENINGS.
  - ALL HANDICAPPED RAMPS OR SIDEWALKS THAT ARE FLUSH SHALL HAVE ADA COMPLIANT TACTILE WARNING STRIPS WHERE ENTERING PARKING AREAS/DRIVEWAYS
  - BUILDING DIMENSIONS ARE APPROXIMATE, REFER TO ARCHITECTURAL DRAWINGS FOR LAYOUT DIMENSIONS.
  - ALL SIDEWALKS 5' WIDE UNLESS OTHERWISE NOTED

- GENERAL NOTES:**
- INSTALL ALL MATERIALS TO MANUFACTURER'S RECOMMENDATIONS AND BEST STANDARDS OF TRADE INVOLVED.
  - SUBSTITUTIONS SHALL BE MADE ONLY WITH OWNER'S APPROVAL AND BE OF EQUIVALENT QUALITY TO WHAT IS SPECIFIED.
  - WORK SHALL BE COMPLETED IN STRICT ACCORDANCE WITH ALL LOCAL CODES AND OSHA SAFETY RULES AND REGULATIONS.
  - VERIFY ALL EXISTING CONDITIONS AND DIMENSIONS AT THE SITE. NOTIFY OWNER & ENGINEER OF DISCREPANCIES IN CONDITIONS SHOWN ON DRAWINGS PRIOR TO PROCEEDING WITH THE WORK.
  - CONTRACTOR SHALL BE RESPONSIBLE FOR PROTECTION OF ANY EXISTING STRUCTURES TO REMAIN AND ANY FINISH MATERIAL INSTALLED WHILE WORKING ON OTHER COMPONENTS.
  - CONTRACTOR SHALL KEEP JOB FREE OF DEBRIS AND MAKE FINAL CLEANUP TO SATISFACTION OF OWNER.
  - CONTRACTOR SHALL ASCERTAIN THE LOCATION OF ALL UTILITIES PRIOR TO CONSTRUCTION SO THAT THIS WORK WILL NOT DISTURB EXISTING LINES AND/OR INSTALLATIONS. COORDINATE ALL WORK WITH THE APPLICABLE UTILITY COMPANIES.
  - CONTRACTOR SHALL OBTAIN AND PAY FOR ALL REQUIRED PERMITS NECESSARY TO PERFORM THE WORK.

- NOTES:**
- CONSTRUCTION SHALL BE IN ACCORDANCE WITH THE TOWN OF ORCHARD PARK'S SPECIFICATIONS WHERE APPLICABLE AND/OR SUBJECT TO THE LATEST REVISIONS BY THE TOWN ENGINEER.
  - FILL SHALL BE PLACED AND SATISFACTORILY COMPACTED PRIOR TO THE INSTALLATION OF WATER AND SEWER LINES (TYPICAL), AND MUST BE APPROVED BY THE SUPERVISING PROJECT ENGINEER.
  - ALL UTILITY LOCATIONS SHOWN ARE APPROXIMATE. CONTRACTOR SHALL VERIFY ALL LOCATION BEFORE BEGINNING WORK AS REQUIRED BY APPLICABLE LAWS AND REGULATIONS.

**SITE LEGEND**

PROPERTY LINE	---
PROPOSED CONCRETE CURB	=====
PROPOSED SIDEWALK / CONCRETE PAD	-----
NUMBER OF PARKING SPACES	(27)
PROPOSED SIGN	▲
PROPOSED STANDARD DUTY ASPHALT PAVEMENT	▨
PROPOSED LIGHT POLE	⊙

**Site Data**

TOTAL SITE AREA = 4.288 ACRES	
ZONED: ZONED I-1 INDUSTRIAL	
BUILDINGS: 45,000 SF PROPOSED MEDICAL OFFICE BUILDING	
<b>SETBACKS - BUILDING</b>	
FRONT:	50 FT 121.63 FT MIN.
SIDE (ABUTTING COMMERCIAL):	NONE 62.75 FT MIN.
REAR:	20 FT N/A
<b>SETBACKS - PARKING</b>	
FRONT:	50 FT 50.86 FT MIN.
SIDE:	• 10.0 FT MIN.
REAR:	• N/A
<b>GREENSPACE</b>	
TOTAL SITE (15%):	15% (0.64 AC) 34.8% (1.49 AC)
INTERIOR OF PARKING AREA: (10%, 41 OR MORE SPACES)	10% (0.17 AC) 10.5% (0.18 AC)
<b>PARKING (TOTAL SITE): 10' x 18'</b>	152 161
<b>MAX. BLDG. HEIGHT:</b>	40 FT < 40 FT

\* AS APPROVED BY THE PLANNING BOARD

**PARKING CALCULATION**

PROFESSIONAL OFFICE:  
 REQ'D = 1 SPACE PER 300 SF OF FLOOR AREA PLUS 1 SPACE FOR EACH SUITE OF OFFICES  
 REQ'D = 45,000 SF / 300 + 2 = 152 SPACES

**Site Plan**  
 SCALE: 1"=40'

- DETAIL LEGEND** SEE SITE DETAIL SHEET
- 1" TYPE "A" CONCRETE CURB
  - 90° PARKING STALL
  - LIGHT POLE FOUNDATION
  - STANDARD DUTY ASPHALT
  - EXTERIOR CONCRETE SLAB ON GRADE
  - HANDICAPPED PAVEMENT MARKINGS
  - HANDICAPPED PARKING SIGN
  - CONCRETE SIDEWALK
  - HANDICAPPED PAVEMENT RAMP
  - DUMPSTER ENCLOSURE
  - RETAINING WALL

- NOTE LEGEND**
- EDGE OF PAVEMENT
  - INSTALL "NO PARKING" SIGN, M.U.T.C.D. SIGN NO. P1-1C
  - LANDSCAPED AREA - SEE LANDSCAPE PLAN, IF NO PLANTINGS, INSTALL TOPSOIL & SEED
  - RUNOUT CURB IN Z OR MATCH EXISTING CURB
  - 1-RISER NEEDED FOR EXIT FROM BUILDING TO SIDEWALK

**CARMINA WOOD**  
 DESIGN  
 Buffalo | Utica | Greensboro

**Medical Office Building**  
 Windward Road  
 Orchard Park, New York

**REVISIONS:**

No.	Description	Date
1	Rev. plan per Town comments	8/17/2023
2	Rev. plan per ECWA comments	8/24/2023
3	Rev. plan per Town comments	9/18/2023

**PERMIT SET**  
 10.06.2023



**DRAWING NAME:**  
 Site Plan

Date: 07.17.23  
 Drawn By: C. Wood  
 Scale: As Noted

**DRAWING NO.:**  
 C-100  
 Project No: 23-4023

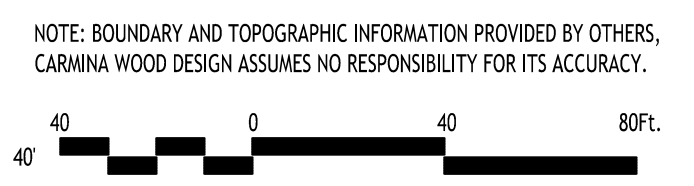

# **Schedule LRA 4/Schedule 7 CON Forms Regarding Environmental issues**

## **Contents:**

**Schedule LRA 4/Schedule 7 - Environmental Assessment**

<b>Environmental Assessment</b>			
<b>Part I.</b>	The following questions help determine whether the project is "significant" from an environmental standpoint.	<b>Yes</b>	<b>No</b>
1.1	If this application involves establishment, will it involve more than a change of name or ownership only, or a transfer of stock or partnership or membership interests only, or the conversion of existing beds to the same or lesser number of a different level of care beds?	<input checked="" type="checkbox"/>	<input type="checkbox"/>
1.2	Does this plan involve construction and change land use or density?	<input checked="" type="checkbox"/>	<input type="checkbox"/>
1.3	Does this plan involve construction and have a permanent effect on the environment if temporary land use is involved?	<input type="checkbox"/>	<input checked="" type="checkbox"/>
1.4	Does this plan involve construction and require work related to the disposition of asbestos?	<input type="checkbox"/>	<input checked="" type="checkbox"/>
<b>Part II.</b>	If any question in Part I is answered "yes" the project may be significant, and Part II must be completed. If all questions in Part II are answered "no" it is likely that the project is not significant	<b>Yes</b>	<b>No</b>
2.1	Does the project involve physical alteration of ten acres or more?	<input type="checkbox"/>	<input checked="" type="checkbox"/>
2.2	If an expansion of an existing facility, is the area physically altered by the facility expanding by more than 50% and is the total existing and proposed altered area ten acres or more?	<input type="checkbox"/>	<input checked="" type="checkbox"/>
2.3	Will the project involve use of ground or surface water or discharge of wastewater to ground or surface water in excess of 2,000,000 gallons per day?	<input type="checkbox"/>	<input checked="" type="checkbox"/>
2.4	If an expansion of an existing facility, will use of ground or surface water or discharge of wastewater by the facility increase by more than 50% and exceed 2,000,000 gallons per day?	<input type="checkbox"/>	<input checked="" type="checkbox"/>
2.5	Will the project involve parking for 1,000 vehicles or more?	<input type="checkbox"/>	<input checked="" type="checkbox"/>
2.6	If an expansion of an existing facility, will the project involve a 50% or greater increase in parking spaces and will total parking exceed 1000 vehicles?	<input type="checkbox"/>	<input checked="" type="checkbox"/>
2.7	In a city, town, or village of 150,000 population or fewer, will the project entail more than 100,000 square feet of gross floor area?	<input type="checkbox"/>	<input checked="" type="checkbox"/>
2.8	If an expansion of an existing facility in a city, town, or village of 150,000 population or fewer, will the project expand existing floor space by more than 50% so that gross floor area exceeds 100,000 square feet?	<input type="checkbox"/>	<input checked="" type="checkbox"/>
2.9	In a city, town or village of more than 150,000 population, will the project entail more than 240,000 square feet of gross floor area?	<input type="checkbox"/>	<input checked="" type="checkbox"/>
2.10	If an expansion of an existing facility in a city, town, or village of more than 150,000 population, will the project expand existing floor space by more than 50% so that gross floor area exceeds 240,000 square feet?	<input type="checkbox"/>	<input checked="" type="checkbox"/>
2.11	In a locality without any zoning regulation about height, will the project contain any structure exceeding 100 feet above the original ground area?	<input type="checkbox"/>	<input checked="" type="checkbox"/>
2.12	Is the project wholly or partially within an agricultural district certified pursuant to Agriculture and Markets Law Article 25, Section 303?	<input type="checkbox"/>	<input checked="" type="checkbox"/>
2.13	Will the project significantly affect drainage flow on adjacent sites?	<input type="checkbox"/>	<input checked="" type="checkbox"/>

2.14	Will the project affect any threatened or endangered plants or animal species?	<input type="checkbox"/>	<input checked="" type="checkbox"/>	
2.15	Will the project result in a major adverse effect on air quality?	<input type="checkbox"/>	<input checked="" type="checkbox"/>	
2.16	Will the project have a major effect on visual character of the community or scenic views or vistas known to be important to the community?	<input type="checkbox"/>	<input checked="" type="checkbox"/>	
2.17	Will the project result in major traffic problems or have a major effect on existing transportation systems?	<input type="checkbox"/>	<input checked="" type="checkbox"/>	
2.18	Will the project regularly cause objectionable odors, noise, glare, vibration, or electrical disturbance as a result of the project's operation?	<input type="checkbox"/>	<input checked="" type="checkbox"/>	
2.19	Will the project have any adverse impact on health or safety?	<input type="checkbox"/>	<input checked="" type="checkbox"/>	
2.20	Will the project affect the existing community by directly causing a growth in permanent population of more than five percent over a one-year period or have a major negative effect on the character of the community or neighborhood?	<input type="checkbox"/>	<input checked="" type="checkbox"/>	
2.21	Is the project wholly or partially within, or is it contiguous to any facility or site listed on the National Register of Historic Places, or any historic building, structure, or site, or prehistoric site, that has been proposed by the Committee on the Registers for consideration by the New York State Board on Historic Preservation for recommendation to the State Historic Officer for nomination for inclusion in said National Register?	<input type="checkbox"/>	<input checked="" type="checkbox"/>	
2.22	Will the project cause a beneficial or adverse effect on property listed on the National or State Register of Historic Places or on property which is determined to be eligible for listing on the State Register of Historic Places by the Commissioner of Parks, Recreation, and Historic Preservation?	<input type="checkbox"/>	<input checked="" type="checkbox"/>	
2.23	Is this project within the Coastal Zone as defined in Executive Law, Article 42? If Yes, please complete Part IV.	<input type="checkbox"/>	<input checked="" type="checkbox"/>	
<b>Part III.</b>		<b>Yes</b>	<b>No</b>	
3.1	Are there any other state or local agencies involved in approval of the project? If so, fill in Contact Information to Question 3.1 below.		<input checked="" type="checkbox"/>	<input type="checkbox"/>
	<b>Agency Name:</b>		Town of Orchard Park Building Department	
	<b>Contact Name:</b>		John Wittman	
	<b>Address:</b>		S 4295 South Buffalo St.	
	<b>State and Zip Code:</b>		Orchard Park, NY 14127	
	<b>E-Mail Address:</b>		WittmanJ@OrchardParkNY.org	
	<b>Phone Number:</b>		716-622-6430 x1405	
	<b>Agency Name:</b>			
	<b>Contact Name:</b>			
	<b>Address:</b>			
	<b>State and Zip Code:</b>			
	<b>E-Mail Address:</b>			
	<b>Phone Number:</b>			
	<b>Agency Name:</b>			
<b>Contact Name:</b>				

	Address:			
	State and Zip Code:			
	E-Mail Address:			
	Phone Number:			
	<b>Agency Name:</b>			
	Contact Name:			
	Address:			
	State and Zip Code:			
	E-Mail Address:			
	Phone Number:			
3.2	Has any other agency made an environmental review of this project? If so, give name, and submit the SEQRA Summary of Findings with the application in the space provided below.		Yes <input type="checkbox"/>	No <input checked="" type="checkbox"/>
	<b>Agency Name:</b>			
	Contact Name:			
	Address:			
	State and Zip Code:			
	E-Mail Address:			
Phone Number:				
3.3	Is there a public controversy concerning environmental aspects of this project? If yes, briefly describe the controversy in the space below.		Yes <input type="checkbox"/>	No <input checked="" type="checkbox"/>
<b>Part IV.</b>	<b>Storm and Flood Mitigation</b>			
	Definitions of FEMA Flood Zone Designations			
	Flood zones are geographic areas that the FEMA has defined according to varying levels of flood risk. These zones are depicted on a community's Flood Insurance Rate Map (FIRM) or Flood Hazard Boundary Map. Each zone reflects the severity or type of flooding in the area.			
	Please use the FEMA Flood Designations scale below as a guide to answering all Part IV questions regardless of project location, flood and or evacuation zone.		Yes	No
4.1	Is the proposed site located in a flood plain? If Yes, indicate classification below and provide the Elevation Certificate (FEMA Flood Insurance).		<input type="checkbox"/>	<input checked="" type="checkbox"/>
	<b>Moderate to Low Risk Area</b>		Yes	No
	<b>Zone</b>	<b>Description</b>	<input type="checkbox"/>	<input checked="" type="checkbox"/>
	In communities that participate in the NFIP, flood insurance is available to all property owners and renters in these zones:			
	<b>B and X</b>	Area of moderate flood hazard, usually the area between the limits of the 100-year and 500-year floods. Are also used to designate base floodplains of lesser hazards, such as areas protected by levees from 100-year flood, or shallow flooding areas with average depths of less than one foot or drainage areas less than 1 square mile.	<input type="checkbox"/>	

<b>C and X</b>	Area of minimal flood hazard, usually depicted on FIRMs as above the 500-year flood level.	<input type="checkbox"/>	
<b>High Risk Areas</b>		<b>Yes</b>	<b>No</b>
<b>Zone</b>	<b>Description</b>	<input type="checkbox"/>	<input checked="" type="checkbox"/>
In communities that participate in the NFIP, mandatory flood insurance purchase requirements apply to all these zones:			
<b>A</b>	Areas with a 1% annual chance of flooding and a 26% chance of flooding over the life of a 30-year mortgage. Because detailed analyses are not performed for such areas; no depths or base flood elevations are shown within these zones.	<input type="checkbox"/>	
<b>AE</b>	The base floodplain where base flood elevations are provided. AE Zones are now used on new format FIRMs instead of A1-A30.	<input type="checkbox"/>	
<b>A1-30</b>	These are known as numbered A Zones (e.g., A7 or A14). This is the base floodplain where the FIRM shows a BFE (old format).	<input type="checkbox"/>	
<b>AH</b>	Areas with a 1% annual chance of shallow flooding, usually in the form of a pond, with an average depth ranging from 1 to 3 feet. These areas have a 26% chance of flooding over the life of a 30-year mortgage. Base flood elevations derived from detailed analyses are shown at selected intervals within these zones.	<input type="checkbox"/>	
<b>AO</b>	River or stream flood hazard areas, and areas with a 1% or greater chance of shallow flooding each year, usually in the form of sheet flow, with an average depth ranging from 1 to 3 feet. These areas have a 26% chance of flooding over the life of a 30-year mortgage. Average flood depths derived from detailed analyses are shown within these zones.	<input type="checkbox"/>	
<b>AR</b>	Areas with a temporarily increased flood risk due to the building or restoration of a flood control system (such as a levee or a dam). Mandatory flood insurance purchase requirements will apply, but rates will not exceed the rates for unnumbered A zones if the structure is built or restored in compliance with Zone AR floodplain management regulations.	<input type="checkbox"/>	
<b>A99</b>	Areas with a 1% annual chance of flooding that will be protected by a Federal flood control system where construction has reached specified legal requirements. No depths or base flood elevations are shown within these zones.	<input type="checkbox"/>	
<b>High Risk Coastal Area</b>		<b>Yes</b>	<b>No</b>
<b>Zone</b>	<b>Description</b>		
In communities that participate in the NFIP, mandatory flood insurance purchase requirements apply to all these zones:			
<b>Zone V</b>	Coastal areas with a 1% or greater chance of flooding and an additional hazard associated with storm waves. These areas have a 26% chance of flooding over the life of a 30-year mortgage. No base flood elevations are shown within these zones.	<input type="checkbox"/>	<input checked="" type="checkbox"/>
<b>VE, V1 - 30</b>	Coastal areas with a 1% or greater chance of flooding and an additional hazard associated with storm waves. These areas have a 26% chance of flooding over the life of a 30-year mortgage. Base flood elevations derived from detailed analyses are shown at selected intervals within these zones.	<input type="checkbox"/>	
<b>Undetermined Risk Area</b>		<b>Yes</b>	<b>No</b>
<b>Zone</b>	<b>Description</b>	<input type="checkbox"/>	<input checked="" type="checkbox"/>



	<b>D</b>	Areas with possible but undetermined flood hazards. No flood hazard analysis has been conducted. Flood insurance rates are commensurate with the uncertainty of the flood risk.		
4.2	Are you in a designated evacuation zone?		<input type="checkbox"/>	<input checked="" type="checkbox"/>
	If Yes, the Elevation Certificate (FEMA Flood Insurance) shall be submitted with the application.			
	If yes which zone is the site located in?			
4.3	Does this project reflect the post Hurricane Lee, and or Irene, and Superstorm Sandy mitigation standards?		<input type="checkbox"/>	<input checked="" type="checkbox"/>
	If Yes, which floodplain?	100 Year	<input type="checkbox"/>	
		500 Year	<input type="checkbox"/>	

The Elevation Certificate provides a way for a community to document compliance with the community's floodplain management ordinance.

**FEMA Elevation Certificate and Instructions**

**New York State Department of Health  
 Certificate of Need Application  
 Schedule 10 - Space & Construction Cost Distribution**

For Article 28, 36, and 40 Construction Projects Requiring Full, Administrative or Limited Review  
 \* Codes for completing this table are found in Schedule 10 lookups sheet.(see tab below)

Indicate if this project is:      New Construction:       Renovation:

A	B	C	D	E	F	G	H	I	
Location				Description of Functional Code (enter Functional code in Column D, description appears here automatically)	Functiona l Gross SF	Construc- tion cost per SF	Total construction cost	Alterat- ions, Scope of work	
Sub project	Building	Floor	section						Functional Code
N/A	Main	1	---	602	FASC	8,059	\$289.77	\$2,335,235	C
<b>Totals for Whole Project:</b>						<b>8,059</b>	<b>\$289.77</b>	<b>\$2,335,235</b>	

If additional sheets are necessary, go to the toolbar, select "Edit", select "Move or copy sheet", make sure the "create a copy" box is checked, and select this document as the destination for the copy then select "OK". An additional worksheet will be added to this spreadsheet

1. If New Construction is Involved, is it "freestanding? N/A	YES	NO
	<input type="checkbox"/>	<input type="checkbox"/>

	Dense Urban	Other metropolitan or suburban	Rural
2. Check the box that best describes the location of the facilities affected by this project:		<input checked="" type="checkbox"/>	<input type="checkbox"/>

The section below must be filled out and signed by the applicant, applicant's representative, project architect, project engineer or project estimator.engineer,

SIGNATURE		DATE	
		12/23/2024	
PRINT NAME		TITLE	
Christopher J. Bartolone, M.D.		Medical Director	
NAME OF FIRM			
Endoscopy Center of Western New York, LLC			
STREET & NUMBER			
60 Maple Road			
CITY	STATE	ZIP	PHONE NUMBER
New York	NY	14221	(716) 332-1000

**Schedule 14 – Additional Legal Information for Article 28 Applicants**

Article 28 applicants seeking establishment or combined establishment and construction approval must complete the relevant section of this Schedule in its entirety.

**Schedule 14A - Business Corporations N/A**

Article 28 applicants seeking establishment or combined establishment and construction approval that are **business corporations** must complete this Section in its entirety.

***N.B.: Whenever a requested legal document has been amended, modified, or restated, all amendment(s), modification(s) and/or restatement(s) should also be submitted.***

- A. **Affidavits:** Attach the originals of stockholder affidavits from each stockholder including the specific information set forth in 10 NYCRR 620.1(b).
- B. **Stock Certificate:** Attach a sample stock certificate including the specific language set forth in 10 NYCRR 620.1(a)(4).

***N.B.: The Certificate of Incorporation must comply with the language requirements set forth in 10 NYCRR 620.1(a).***

- C. **Limited Liability Corporation Stockholders:** Does the applicant have any stockholders that are limited liability companies (LLCs)? Yes  No

**If Yes**, identify each LLC-stockholder in the following table or by uploading a table as an attachment to this Schedule. Attachment #

Name of LLC Shareholder	Address

**New York State Department of Health  
Certificate of Need Application**

**Schedule 14A**

**D. Documentation for LLC Stockholders:** For each LLC-stockholder (2nd Level Stockholder), attach the following documentation:

1. A list providing the name, membership interest and percentage ownership interest in the 2nd Level Stockholder and indirect ownership percentage in the Article 28 business corporation. (Indirect ownership is determined by multiplying the percentage of ownership in each entity. For example, if A owns 10 percent of a 2nd Level Stockholder which itself owns 80 percent of an Article 28 business corporation, A owns an indirect ownership interest of eight percent in the Article 28 business corporation.) for each member;

***N.B.: All members of the 2nd Level Stockholder must be natural persons.***

2. A list of all members and managers;
3. Articles of Organization; and
4. Operating Agreement.

**E. Articles of Organization:** In addition to any other provisions required by the Limited Liability Company Law, the Articles of Organization of the 2nd Level Stockholder must include provisions to the following effect:

1. That all members of must be natural persons and that this provision may not be deleted, modified or amended without the prior approval of the New York State Department of Health; and
2. That notwithstanding anything to the contrary in the Articles of Organization or the Operating Agreement, transfers, assignments or other dispositions of membership interests or voting rights must be effectuated in accordance with section 2801-a(4)(c) of the Public Health Law and that this provision may not be deleted, modified or amended without the prior approval of the New York State Department of Health.

**F. Operating Agreement:** The Operating Agreement of the 2nd Level Stockholder must include provisions to the following effect:

1. That all members must be natural persons and that this provision may not be deleted, modified or amended without the prior approval of the New York State Department of Health;
2. That notwithstanding anything to the contrary in the Articles of Organization or the Operating Agreement, transfers, assignments or other dispositions of membership interests or voting rights must be effectuated in accordance with section 2801-a(4)(c) of the Public Health Law and that this provision may not be deleted, modified or amended without the prior approval of the New York State Department of Health; and
3. That, if the 2nd Level Stockholder will be managed by managers who are not members, the following powers with respect to the ownership and operation of the Article 28 business corporation are reserved to the members of the 2nd Level Stockholder:
  - a. direct independent authority over the appointment or dismissal of hospital management-level employees and medical staff,
  - b. approval of hospital operating and capital budgets and independent control of the books and records,
  - c. adoption or approval of hospital operating policies and procedures and independent adoption of policies affecting the delivery of health care services,

**New York State Department of Health  
Certificate of Need Application**

**Schedule 14A**

- d. authority over the disposition of assets and authority to incur liabilities not normally associated with day-today operations,
- e. approval of certificate of need applications filed by or on behalf of the hospital,
- f. approval of hospital debt necessary to finance the cost of compliance with operational or physical plant standards required by law,
- g. approval of hospital contracts for management or for clinical services, and
- h. approval of settlements of administrative proceedings or litigation to which the hospital is a party, and that this provision may not be deleted, modified or amended without the prior approval of the Department of Health.

**SCHEDULE 14A CHECKLIST OF ATTACHMENTS**

DOCUMENT	NA	Attach ed	Attachment number	Electronic Document file name
<b>Business Corporations</b>				
Stockholder affidavits	<input type="checkbox"/>	<input type="checkbox"/>		
Sample stock certificate	<input type="checkbox"/>	<input type="checkbox"/>		
<b>Stockholder-LLCs</b>				
List of members	<input type="checkbox"/>	<input type="checkbox"/>		
List of managers	<input type="checkbox"/>	<input type="checkbox"/>		
Articles of Organization	<input type="checkbox"/>	<input type="checkbox"/>		
Operating Agreement	<input type="checkbox"/>	<input type="checkbox"/>		

## Schedule 14B - Limited Liability Companies

Article 28 applicants seeking establishment or combined establishment and construction approval that are **limited liability companies** must complete this Section in its entirety.

***N.B.: Whenever a requested legal document has been amended, modified, or restated, all amendment(s), modification(s) and/or restatement(s) should also be submitted.***

### I. Articles of Organization

Provisions to the following effect must be included:

- A. The name of the LLC which must contain either the words "Limited Liability Company" or the abbreviations "LLC" or "L.L.C.";
- B. Designation of the Secretary of State as agent of the LLC for service of process and an address to which the Secretary of State may mail a copy of any such process;
- C. How the LLC will be managed and that neither the management structure nor the provision setting forth such structure may be deleted, modified or amended without the prior approval of the New York State Department of Health;
- D. If the LLC will be managed by managers who are not members, that the manager may not be changed without the prior approval of the New York State Department of Health;
- E. That the powers and purposes of the LLC are limited to the ownership and operation of the Article 28 facility specifically named and the location of the facility by street address, city, town, village or locality and county;

***N.B.: The powers and purposes may also include the operation of an Article 36 facility, an Article 40 facility and/or an Article 44 entity if the applicant has received all appropriate approvals and certifications.***

- F. The location of the principal office of the LLC, which must be the same address as the facility; and
- G. That notwithstanding anything to the contrary in the Articles of Organization or the Operating Agreement, transfers, assignments or other dispositions of New York State Department of Health membership interests or voting rights must be effectuated in accordance with section 2801-a(4)(b) of the Public Health Law.

### II. Operating Agreement

Provisions to the following effect must be included:

- A. That the powers and purposes of the LLC are limited to the ownership and operation of the Article 28 facility specifically named and the location of the facility by street address, city, town, village or locality and county;
- B. That notwithstanding anything to the contrary in the Articles of Organization or the Operating Agreement, transfers, assignments or other dispositions of membership interests or voting rights must be effectuated in accordance with section 2801-a(4)(b) of the Public Health Law;
- C. How the LLC will be managed and that neither the management structure nor the provision setting forth such structure may be deleted, modified or amended without the prior approval of the Department of Health;
- D. If the LLC will be managed by managers who are not members, that the manager may not be changed without the prior approval of the Department of Health; and

**New York State Department of Health  
Certificate of Need Application**

**Schedule 14B**

- E. If the LLC will be managed by managers who are not members, that the following powers are reserved to the members:
1. direct independent authority over the appointment or dismissal of hospital management-level employees and medical staff;
  2. approval of hospital operating and capital budgets and independent control of the books and records;
  3. adoption or approval of hospital operating policies and procedures and independent adoption of policies affecting the delivery of health care services;
  4. authority over the disposition of assets and authority to incur liabilities not normally associated with day-to-day operations;
  5. approval of certificate of need applications filed by or on behalf of the hospital;
  6. approval of hospital debt necessary to finance the cost of compliance with operational or physical plant standards required by law;
  7. approval of hospital contracts for management or for clinical services; and
  8. approval of settlements of administrative proceedings or litigation to which the hospital is a party.

**III. Management**

Will the applicant be managed by managers who are not members? Yes  No

By letter dated March 23, 2015 from ECWNY, LLC to Ms. Barbara DelCogliano of the Department, Mr. Robert Estes was appointed as an Outside Manager to serve on the Center's Board of Managers, and Mr. Estes has served in this capacity since that time. The Outside Manager Agreement and C.O.N. Schedule 2A for Mr. Estes were submitted with the letter to the Department on March 23, 2015.

**If Yes**, attach the proposed Management Agreement between the applicant and the manager, which must meet the following requirements and be approved by the Commissioner.

- A. The management agreement must include provisions to the following effect:
1. A description of the proposed roles of the members of the Article 28 LLC during the period of the proposed management contract, which must clearly reflect retention by the members of ongoing responsibility for statutory and regulatory compliance,
  2. A provision that clearly recognizes that the responsibilities of the members of the Article 28 LLC are in no way obviated by entering into a management agreement and that any powers not specifically delegated to the manager through the provisions of the management agreement remain with the members,
  3. The following powers are reserved to the members of the Article 28 LLC:
    - a. direct independent authority over the appointment or dismissal of hospital management-level employees and medical staff;
    - b. approval of hospital operating and capital budgets and independent control of the books and records;
    - c. adoption or approval of hospital operating policies and procedures and independent adoption of policies affecting the delivery of health care services;
    - d. authority over the disposition of assets and authority to incur liabilities not normally associated with day-today operations;
    - e. approval of certificate of need applications filed by or on behalf of the hospital;



- f. approval of hospital debt necessary to finance the cost of compliance with operational or physical plant standards required by law;
  - g. approval of hospital contracts for management or for clinical services; and
  - h. approval of settlements of administrative proceedings or litigation to which the hospital is a party; and that this provision may not be deleted; modified or amended without the prior approval of the Department of Health.
4. The following language:
- "Notwithstanding any other provision in this contract, the facility remains responsible for ensuring that any service provided pursuant to this contract complies with all pertinent provisions of Federal, State and local statutes, rules and regulations.",
5. A plan for assuring maintenance of the fiscal stability, the level of services provided and the quality of care rendered by the facility during the term of the management agreement, and
6. Retention of authority by the members of the Article 28 LLC to discharge the manager and its employees from their positions at the facility with or without cause on not more than 90 days' notice. In such event, the facility shall notify the Department in writing at the time the manger is notified. The members of the Article 28 LLC must provide a plan for the operation of the facility subsequent to the discharge of the manager and such plan must be submitted with the notification to the Department.
7. That the manager may not be changed and its responsibilities and obligations under the management agreement may not be subcontracted, assigned or otherwise assumed without the prior approval of the Department of Health;
- B. The members of the Article 28 LLC must retain sufficient authority and control to discharge its statutory and regulatory responsibility. The following powers must be specifically reserved to the Article 28 LLC members:
- 1. Direct independent authority over the appointment or dismissal of the facility's management-level employees and medical staff,
  - 2. Approval of the facility's operating and capital budgets and independent control of the books and records,
  - 3. Adoption or approval of the facility's operating policies and procedures and independent adoption of policies affecting the delivery of health care services,
  - 4. Authority over the disposition of assets and authority to incur liabilities not normally associated with day-to-day operations,
  - 5. Approval of certificate of need applications filed by or on behalf of the facility,
  - 6. Approval of debt necessary to finance the cost of compliance with operational or physical plant standards required by law,
  - 7. Approval of the facility's contracts for management or for clinical services, and
  - 8. Approval of settlements of administrative proceedings or litigation to which the facility is a party;

# New York State Department of Health Certificate of Need Application

## Schedule 14B

- C. An Article 28 LLC desiring to be managed by managers who are not members must submit a proposed written management agreement to the Department at least 60 days before the intended effective date, unless a shorter period is approved in writing by the Commissioner, due to extraordinary circumstances. In addition, the Article 28 LLC shall also submit, within the same time frame, the following:
1. Documentation demonstrating that the proposed manager holds all necessary approvals to do business within New York,
  2. Documentation of the goals and objectives of the management arrangement, including a mechanism for periodic evaluation by the members of the Article 28 LLC of the effectiveness of the arrangement in meeting those goals and objectives,
  3. Evidence of the manager's financial stability,
  4. Information necessary to determine that the character and competence of the proposed manager, and its principals, officers and directors, are satisfactory, including evidence that all facilities it has managed within New York have provided a substantially consistent high level of care in accordance with applicable statutes and regulations, during the term of any management agreement contract or the period they held an operating certificate, and
  5. Evidence that it is financially feasible for the facility to enter into the proposed management agreement for the term of the agreement and for a period of one year following expiration, recognizing that the costs of the agreement are subject to all applicable provisions of Part 86 of 10 NYCRR. To demonstrate evidence of financial feasibility, the facility shall submit projected operating and capital budgets for the required periods. Such budgets shall be consistent with previous certified financial statements and be subject to future audits;
- D. During the period between a facility's submission of a request for initial approval of a management contract and disposition of that request, a facility may not enter into any arrangement for management contract services other than a written interim consultative agreement with the proposed manager. Any interim agreement must be consistent with these provisions and submitted to the Department no later than five days after its effective date.
- E. The term of a management contract shall be limited to three years and may be renewed for additional periods not to exceed three years only when authorized by the Commissioner. The Commissioner shall approve an application for renewal provided that compliance with this section and the following provisions can be demonstrated:
1. That the goals and objectives of the arrangement have been met within specified time frames,
  2. That the quality of care provided by the facility during the term of the arrangement has been maintained or has improved, and
  3. That the level of service to meet community needs and patient access to care and services has been maintained or improved.

**New York State Department of Health  
Certificate of Need Application**

**Schedule 14B**

**IV. Membership Certificates**

Does the applicant intend to issue membership certificates? Yes  No

If Yes, attach a sample membership certificate including the following legend:

"That notwithstanding anything to the contrary in the Articles of Organization or the Operating Agreement, transfers, assignments or other dispositions of membership interests or voting rights must be effectuated in accordance with section 2801-a(4)(b) of the Public Health Law."

**V. Business Corporation Members**

Does the applicant have any members which are business corporations? Yes  No

If Yes:

A. Identify each business corporation-member (2<sup>nd</sup> level member) in the following table or by uploading a table as an attachment to this Schedule. Attachment #

2 <sup>nd</sup> Level Member:	Address

B. For each business corporation-member, attach the following documentation:

1. A list providing the name, stock interest and percentage ownership interest in the 2nd Level Member and indirect ownership percentage in the Article 28 LLC for each stockholder. (Indirect ownership is determined by multiplying the percentage of ownership in each entity. For example, if A owns 10 percent of a 2nd Level Member which itself owns 80 percent of an Article 28 LLC, A owns an indirect ownership interest of eight percent in the Article 28 LLC.);

***N.B.: All stockholders of the 2nd Level Member must be natural persons.***

2. A list providing the name and position held for each officer and director; and
3. Certificate of Incorporation. In addition to any other provisions required by the Business Corporation Law, the Certificate of Incorporation of the 2nd Level Member must include provisions to the following effect:
  - a. That all stockholders must be natural persons and that this provision may not be deleted, modified or amended without the prior approval of the New York State Department of Health; and

**New York State Department of Health  
Certificate of Need Application**

**Schedule 14B**

- b. That notwithstanding anything to the contrary in the Certificate of Incorporation or the Bylaws, transfers, assignments or other dispositions of ownership interests or voting rights must be effectuated in accordance with section 2801-a(4)(b) of the Public Health Law and that this provision may not be deleted, modified or amended without the prior approval of the New York State Department of Health.

**VI. General or Registered Limited Liability Partnership Members**

Does the applicant have any members which are general or registered limited liability partnerships?  
Yes  No

**If Yes:**

- A. Identify each partnership-member (2<sup>nd</sup> level member) in the following table or by uploading a table as an attachment to this Schedule. Attachment #

2 <sup>nd</sup> Level Member:	Address

- B. For each partnership-member, attach the following documentation:

- 1 A list providing the name, partnership interest and percentage ownership interest in the 2nd Level Member and indirect ownership percentage in the Article 28 LLC for each partner. (Indirect ownership is determined by multiplying the percentage of ownership in each entity. For example, if A owns 10 percent of a 2nd Level Member which itself owns 80 percent of an Article 28 LLC, A owns an indirect ownership interest of eight percent in the Article 28 LLC.); and

***N.B.: All partners of the 2nd Level Member must be natural persons.***

- 2 The Partnership Agreement of the 2nd Level Member must include provisions to the following effect:
  - a. That all partners must be natural persons and that this provision may not be deleted, modified or amended without the prior approval of the New York State Department of Health;

**New York State Department of Health  
Certificate of Need Application**

**Schedule 14B**

- b. That transfers, assignments or other dispositions of partnership interests or voting rights must be effectuated in accordance with section 2801-a(4)(b) of the Public Health Law and that this provision may not be deleted, modified or amended without the prior approval of the New York State Department of Health;
- c. Contain the language set forth in 10 NYCRR 600.1(b)(5)(ii).

**VII. Not-for-Profit Corporation Members**

Does the applicant have any members which are not-for-profit corporations? Yes  No

**If Yes:**

A. Identify each not-for-profit corporation-member (2<sup>nd</sup> Level Member) in this table or by uploading a table as an attachment to this Schedule. Attachment #

2nd Level Member:	Address

B. For each not-for-profit corporation-member, attach the following documentation:

- 1 A list providing the name and interest or position held for each member, director, and officer;
- 2 Certificate of Incorporation; and
- 3 Bylaws.

C. Are any of the following powers reserved to any of the corporation's member(s):

- Appointment or dismissal of hospital management-level employees and medical staff, except the election or removal of corporate officers.

Yes  No

Member:

- Approval of hospital operating and capital budgets.

Yes  No

Member:

**New York State Department of Health  
Certificate of Need Application**

**Schedule 14B**

- Adoption or approval of hospital operating policies and procedures.

Yes  No

Member:

- Approval of certificate of need applications filed by or on behalf of the hospital

Yes  No

Member:

**If Yes**, attach documentation of approval for this application.

- Approval of hospital debt necessary to finance the cost of compliance with operational or physical plant standards required by law.

Yes  No

Member:

- Approval of hospital contracts for management or for clinical services.

Yes  No

Member:

- Approval of settlements of administrative proceedings or litigation to which the hospital is a party, except approval of settlements of litigation that exceed insurance coverage or any applicable self-insurance fund.

Yes  No

Member:

**N.B.:** If any of the corporation's members have been or will be delegated any of these powers, the member itself must have or obtain establishment approval as an active 2<sup>nd</sup> level member. If so, submit Schedule 2A for each individual listed in item VII(B)(1) above. Directors who contribute capital in support of the project must also submit Schedule 2B. Directors who do not contribute capital in support of the project must also submit Schedule 2C.

**New York State Department of Health  
Certificate of Need Application**

**VIII. Limited Liability Company Members**

Does the applicant have any members which are also LLCs? Yes  No

**If Yes:**

A. Identify each LLC 2<sup>nd</sup> level member in this table or by uploading a table as an attachment to this Schedule. Attachment #

2 <sup>nd</sup> Level Member	Address
60 Holdco, LLC, an existing member of Endoscopy Center of Western New York, LLC. (Please see the Schedule 3 Attachment for a list of the members of 60 Holdco, LLC)	CT Corporation System 28 Liberty Street New York, NY 10005
PE Healthcare Associates, LLC, an existing member of Endoscopy Center of Western New York, LLC. The members of PE Healthcare Associates, LLC are: Ann Sariego (33.33%); Rafael Axen, M.D. (33.33%); and Matthew Jenkins (33.33%).	535 Fifth Avenue, 4 <sup>th</sup> Floor New York, NY 10017

**New York State Department of Health  
Certificate of Need Application**

**Schedule 14B**

- B. For each LLC-member, attach the following documentation: Please see Schedule 3 Attachments
- 1 A list providing the name, membership interest and percentage ownership interest in the 2nd Level Member and indirect ownership percentage in the Article 28 LLC. (Indirect ownership is determined by multiplying the percentage of ownership in each entity. For example, if A owns 10 percent of a 2nd Level Member which itself owns 80 percent of an Article 28 LLC, A owns an indirect ownership interest of eight percent in the Article 28 LLC.)
- N.B.: All members of the 2nd Level Member must be natural persons.***
- 2 A list of all members and managers;
  - 3 Articles of Organization; and
  - 4 Operating Agreement.
- C. In addition to any other provisions required by the Limited Liability Company Law, the Articles of Organization of the 2nd Level Member must include provisions to the following effect:
- 1 That all members must be natural persons and that this provision may not be deleted, modified or amended without the prior approval of the New York State Department of Health;
  - 2 That transfers, assignments or other dispositions of membership interests or voting rights must be effectuated in accordance with section 2801-a(4)(b) of the Public Health Law and that this provision may not be deleted, modified or amended without the prior approval of the New York State Department of Health.
- D. The Operating Agreement of the 2nd Level Member must include provisions to the following effect:
- 1 That all members must be natural persons and that this provision may not be deleted, modified or amended without the prior approval of the New York State Department of Health,
  - 2 That notwithstanding anything to the contrary in the Articles of Organization or the Operating Agreement, transfers, assignments or other dispositions of membership interests or voting rights must be effectuated in accordance with section 2801-a(4)(b) of the Public Health Law and that this provision may not be deleted, modified or amended without the prior approval of the New York State Department of Health; and
  - 3 That, if the 2nd Level Member will be managed by managers who are not members, that the following powers with respect to the ownership and operation of the Article 28 LLC are reserved to the members of the 2nd Level Member:
    - a. direct independent authority over the appointment or dismissal of hospital management-level employees and medical staff;
    - b. approval of hospital operating and capital budgets and independent control of the books and records;
    - c. adoption or approval of hospital operating policies and procedures and independent adoption of policies affecting the delivery of health care services;
    - d. authority over the disposition of assets and authority to incur liabilities not normally associated with day-today operations;
    - e. approval of certificate of need applications filed by or on behalf of the hospital;
    - f. (approval of hospital debt necessary to finance the cost of compliance with operational or physical plant standards required by law;



**New York State Department of Health  
Certificate of Need Application**

**Schedule 14B**

- g. approval of hospital contracts for management or for clinical services; and
- h. approval of settlements of administrative proceedings or litigation to which the hospital is a party; and that this provision may not be deleted; modified or amended without the prior approval of the Department of Health.

**New York State Department of Health  
Certificate of Need Application**

**Schedule 14B**

**SCHEDULE 14B CHECKLIST OF ATTACHMENTS**

DOCUMENT	NA	Attached	Attachment number	Electronic Document file name
Management Agreement	<input checked="" type="checkbox"/>	<input type="checkbox"/>		
Sample membership certificate	<input checked="" type="checkbox"/>	<input type="checkbox"/>		
<b>Business Corporation- Members</b>				
Members	<input checked="" type="checkbox"/>	<input type="checkbox"/>		
List of stockholders	<input checked="" type="checkbox"/>	<input type="checkbox"/>		
List of officers and directors	<input checked="" type="checkbox"/>	<input type="checkbox"/>		
Certificate of Incorporation	<input checked="" type="checkbox"/>	<input type="checkbox"/>		
<b>Not-for-Profit Corporation- Members</b>				
Members	<input checked="" type="checkbox"/>	<input type="checkbox"/>		
List of members	<input checked="" type="checkbox"/>	<input type="checkbox"/>		
List of officers and directors	<input checked="" type="checkbox"/>	<input type="checkbox"/>		
Certificate of Incorporation	<input checked="" type="checkbox"/>	<input type="checkbox"/>		
Bylaws	<input checked="" type="checkbox"/>	<input type="checkbox"/>		
Documentation of approval for the application	<input checked="" type="checkbox"/>	<input type="checkbox"/>		
<b>Limited Liability Company - Members</b>				
Members	<input type="checkbox"/>	<input checked="" type="checkbox"/>	Schedule 3 Attachments	
List of members	<input type="checkbox"/>	<input checked="" type="checkbox"/>	Schedule 3 Attachments	
List of managers	<input type="checkbox"/>	<input checked="" type="checkbox"/>	Schedule 3 Attachments	
Articles of Organization	<input type="checkbox"/>	<input checked="" type="checkbox"/>	Schedule 3 Attachments	
Operating Agreement	<input type="checkbox"/>	<input checked="" type="checkbox"/>	Schedule 3 Attachments	
<b>General or Registered Limited Liability Company - Members</b>				
List of Partners	<input checked="" type="checkbox"/>	<input type="checkbox"/>		
Partnership Agreement	<input checked="" type="checkbox"/>	<input type="checkbox"/>		

**Schedule 14C - Not-For-Profit Corporations N/A**

Article 28 applicants seeking establishment or combined establishment and construction approval that are *not-for-profit corporations* must complete this Section in its entirety.

***N.B.: Whenever a requested legal document has been amended, modified, or restated, all amendment(s), modification(s) and/or restatement(s) should also be submitted.***

**I. Directors**

A. Number of director positions set by bylaws or otherwise fixed:

(See Not-for-Profit Corporation Law 702.)

B. Number of director positions currently filled:

C. Explain how and by whom the directors will be appointed or elected:

**II. Members**

A. Identify each member of the applicant in this table or by uploading a table as an attachment to this Schedule. Attachment #

Member:	Address

**New York State Department of Health  
Certificate of Need Application**

**Schedule 14C**

B. If applicable, for each member, attach the following documentation:

1. A list of the name and position held for each officer and director;
2. Certificate of Incorporation; and
3. Bylaws.

**III. Reserved Powers**

A. Are or will any of the following powers be reserved to any of the applicant's member(s):

- Appointment or dismissal of hospital management-level employees and medical staff, except the election or removal of corporate officers.

Yes  No

Member:

- Approval of hospital operating and capital budgets.

Yes  No

Member:

- Adoption or approval of hospital operating policies and procedures.

Yes  No

Member:

- Approval of certificate of need applications filed by or on behalf of the hospital

Yes  No

Member:

**If Yes**, attach documentation of approval for this application.

- Approval of hospital debt necessary to finance the cost of compliance with operational or physical plant standards required by law.

Yes  No

Member:

- Approval of hospital contracts for management or for clinical services.

Yes  No

Member:

**New York State Department of Health  
Certificate of Need Application**

**Schedule 14C**

- Approval of settlements of administrative proceedings or litigation to which the hospital is a party, except approval of settlements of litigation that exceed insurance coverage or any applicable self-insurance fund.

Yes  No

Member:

**N.B.:** If any of the applicant’s members have been or will be delegated any of these powers, the member itself must have or obtain establishment approval. If so, submit Schedule 2a for each individual listed in item II(B)(1) above. Directors who contribute capital to the project must also submit Schedule 2b. Directors who do not contribute capital to the project must also submit Schedule 2c.

B. Do any of the applicant’s members reserve the power to approve certificate of need applications to ensure that they conform to the facility’s stated mission and philosophy?

Yes  No

Member:

**If Yes,** attach documentation of approval for this application.

**SCHEDULE 14C CHECKLIST OF ATTACHMENTS**

DOCUMENT	NA	Attached	Attachment number	Electronic Document file name
Members	<input type="checkbox"/>	<input type="checkbox"/>		
List of officers and directors	<input type="checkbox"/>	<input type="checkbox"/>		
Certificate of Incorporation	<input type="checkbox"/>	<input type="checkbox"/>		
Bylaws	<input type="checkbox"/>	<input type="checkbox"/>		

**Schedule 14D - General or Registered Limited Liability Partnerships N/A**

Article 28 applicants seeking establishment or combined establishment and construction approval that are **general or registered limited liability partnerships** must complete this Section in its entirety.

1. The language in Section A of this schedule must be included in the Partnership Agreements for Article 28 applicants seeking establishment or combined establishment and approval that are partnerships.
2. The language in section B of this schedule must be included in the Certificate of Registration for Article 28 applicants seeking establishment or combined establishment and construction approval that are registered limited liability partnerships.

***N.B.: Whenever a requested legal document has been amended, modified, or restated, all amendment(s), modification(s) and/or restatement(s) should also be submitted.***

- A. Partnership Agreement – The language in section 600.1(b)(5)(ii) of 10 NYCRR must be included in its entirety for general or registered limited liability partnerships.
- B. Certificate of Registration – must include provisions to the following effect::
  1. That the powers and purposes specifically include the ownership and operation of the facility and the name of the facility; and
  2. That, notwithstanding anything to the contrary in the Certificate of Partnership agreement, transfers, assignments or other dispositions of partnership interests or voting rights must be effectuated in accordance with section 2801-4(b) of the PHL.

**SCHEDULE 14D CHECKLIST OF ATTACHMENTS**

DOCUMENT	NA	Attached	Attachment number	Electronic Document file name
Certificate of Registration	<input type="checkbox"/>	<input type="checkbox"/>		

## Schedule 15 - Additional Legal Information - Ownership Transfers

### Instructions:

Article 28 applicants seeking full establishment approval for a change in ownership through an ownership interest transfer or by a change in active member must complete this schedule\*, depending on the applicant's legal entity, as follows:

1. Applicants that are **general partnerships** must complete **Part I**.
2. Applicants that are **registered limited liability partnerships** must complete **Part II**.
3. Applicants that are **not-for-profit corporations** seeking approval for a change in **active member** must complete **Part III**.
4. Applicants that are **business corporations** must complete **Part IV**.
5. Applicants that are **limited liability companies** must complete **Part V**.

***N.B.: Whenever a requested legal document has been amended, modified, or restated, all amendment(s), modification(s) and/or restatement(s) should also be submitted.***

Pursuant to section PHL 2801-a(2-a), a change in an existing Article 28 legal entity to a limited liability company or a business corporation does not require CON approval but may be approved administratively, under the following circumstances:

1. the Certificate of Incorporation or Articles of Organization reflect solely a change in the form of business organization approved by the Public Health and Health Planning Council or its predecessor;
2. every stockholder, incorporator, sponsor, member, and director of the proposed entity was similarly, an owner, partner, stockholder, incorporator, sponsor, member, or director of the existing entity;
3. the distribution of ownership interests and voting rights in the proposed entity is identical to the existing entity;
4. there is no change in the operator of an Article 28 facility other than the form of business entity; and
5. the proposed entity has site control and all required assets to own and operate the Article 28 facility.

\* Refer to Department of Health Guidance regarding when a Transfer of Ownership Interest Notice may be submitted in place of this Schedule.

### I. General Partnerships

**N.B.: Only transfers of partnership interests of ten percent or more to a new partner require CON approval.** Transfers of less than ten percent to a new partner require prior notice. See PHL 2801-a(4)(b).

A. Attach the following legal documentation:

1. A list providing the following information for each incoming partner: name, partnership interest, and percentage ownership being acquired;
2. Documentation of the transfer of partnership interest;
3. Partnership Agreement, including documentation that each incoming partner will be legally bound by the Agreement;
4. A list of the names, partnership interest and percentage ownership for all partners before and after the proposed transfer;
5. Certificate of Assumed Name, as filed; and
6. Documentation of consent of the existing partners, if necessary; and

B. Submit Schedules 2A and 2B for each incoming partner.

### II. Registered Limited Liability Partnerships

**N.B.: Only transfers of partnership interests of ten percent or more to a new partner require CON approval.** Transfers of less than ten percent to a new partner require prior notice. See PHL 2801-a(4)(b).

A. Attach the following legal documentation:

1. A list providing the following information for each incoming partner: name, partnership interest, and percentage ownership being acquired;
2. Documentation of the transfer of partnership interest;
3. Partnership Agreement, including documentation that each incoming partner will be legally bound by the Agreement;
4. Certificate of Registration;
5. A list of the names, partnership interest and percentage ownership for all partners before and after the proposed transfer;
6. Certificate of Assumed Name, as filed;
7. Fully executed proposed Certificate of Amendment to the Certificate of Registration reflecting the change(s) in partner(s);
7. Documentation of consent of the existing partners, if necessary; and

B. Submit Schedules 2A and 2B for each incoming partner.



**III. Not-for-Profit Corporations**

Change in Active Member

**N.B.: A change in active member requires CON approval. A member is active if it has any of the following reserved powers with respect to the Article 28 corporation:**

1. Appointment or dismissal of hospital management-level employees and medical staff, except the election or removal of corporate officers.
2. Approval of hospital operating and capital budgets.
3. Adoption or approval of hospital operating policies and procedures.
4. Approval of certificate of need applications filed by or on behalf of the hospital.
5. Approval of hospital debt necessary to finance the cost of compliance with operational or physical plant standards required by law.
6. Approval of hospital contracts for management or for clinical services.
7. Approval of settlements of administrative proceedings or litigation to which the hospital is a party, except approval of settlements of litigation that exceed insurance coverage or any applicable self-insurance fund.

A change in a passive member does not require CON approval. If the change in passive member results in a change in officers and/or directors of the Article 28 corporation, however, such changes must be reported in the facility's annual report statement pursuant to 10 NYCRR 610.3.

**A. Attach the following legal documentation:**

With respect to the Article 28 corporation:

1. Certificate of Incorporation, as filed;
2. Fully executed proposed Certificate of Amendment reflecting the delegation of powers to the active member;
3. Bylaws;
4. Proposed amendments to Bylaws, if any; and

With respect to the proposed active member corporation:

1. Certificate of Incorporation, as filed;
2. Fully executed proposed Certificate of Amendment reflecting the delegation of active powers from the Article 28 corporation;
3. Bylaws;
4. Proposed amendments to Bylaws, if any;
5. Board Resolution(s); and
6. A list of names and position held for all officers and directors; and

**B. Submit Schedule 2A for each individual listed in item 5e above. Directors of a not-for profit corporation who contribute capital in support of the project must also submit Schedule 2B. Directors of a not-for-profit corporation who do not contribute capital in support of the project must also submit Schedule 2C.**

# New York State Department of Health Certificate of Need Application

## Schedule 15

### IV. Business Corporations

**N.B.: Only transfers of ten percent or more of stock interests or voting rights to a new stockholder and transfers which result in an individual, who has not yet been established, becoming an owner of ten percent or more require CON approval.** Transfers of ten percent or more to an existing stockholder who has previously been approved by the Public Health and Health Planning Council require prior notice. See PHL 2801-a(4)(c).

A. Attach the following legal documentation:

1. A list providing the following information for each incoming stockholder: name, stock interest, and percentage ownership being acquired;
2. Documentation of the transfer of stock;
3. Certificate of Incorporation;
4. Bylaws;
5. Board Resolution;
6. A list of the names, stock interest and percentage ownership for all stockholders before and after the proposed transfer; and
7. Original of stock transfer affidavit from each incoming stockholder and each selling stockholder, including the specific information set forth in 10 NYCRR 620.3(a)(2) and (3), respectively; and

B. Submit Schedules 2A and 2B for each incoming stockholder.

### V. Limited Liability Companies

**N.B.: Only transfers of membership interests of ten percent or more to a new member require CON approval.** Transfers of less than ten percent to a new member only require prior notice. See PHL 2801-a(4)(b).

A. Attach the following legal documentation:

#### **Schedule 3 Attachments**

1. A list providing the following information for each incoming member: name, membership interest, and percentage ownership being acquired;
2. Documentation of the transfer of membership interest;
3. Articles of Organization;
4. Operating Agreement, including documentation that each incoming member will be legally bound by it;
5. A list of the names, membership interest and percentage ownership for all members before and after the proposed transfer;
6. Documentation of consent of existing members, if necessary; and

B. Submit Schedules 2A and 2B for each incoming member. **Provided with Application**

**New York State Department of Health  
Certificate of Need Application**

**Schedule 15**

**Checklist of Attachments to Schedule 15**

<b>DOCUMENTATION</b>	<b>NA</b>	<b>Attached</b>	<b>Attachment number</b>	<b>Electronic Document file name</b>
<b>I. General Partnerships</b>				
List regarding each incoming partner	<input checked="" type="checkbox"/>	<input type="checkbox"/>		
Evidence of transfer of partnership interest	<input checked="" type="checkbox"/>	<input type="checkbox"/>		
Partnership Agreement, including documentation by incoming partner(s)	<input checked="" type="checkbox"/>	<input type="checkbox"/>		
List regarding all partners (before and after)	<input checked="" type="checkbox"/>	<input type="checkbox"/>		
Certificate of Doing Business as a Partnership	<input checked="" type="checkbox"/>	<input type="checkbox"/>		
Certificate of Amendment	<input checked="" type="checkbox"/>	<input type="checkbox"/>		
Consent of existing partners	<input checked="" type="checkbox"/>	<input type="checkbox"/>		
<b>II. Registered Limited Liability Partnerships</b>				
List regarding each incoming partner	<input checked="" type="checkbox"/>	<input type="checkbox"/>		
Evidence of transfer of partnership interest	<input checked="" type="checkbox"/>	<input type="checkbox"/>		
Partnership Agreement, including documentation by incoming partner(s)	<input checked="" type="checkbox"/>	<input type="checkbox"/>		
Certificate of Registration	<input checked="" type="checkbox"/>	<input type="checkbox"/>		
List regarding all partners (before and after)	<input checked="" type="checkbox"/>	<input type="checkbox"/>		
Certificate of Doing Business as a Partnership	<input checked="" type="checkbox"/>	<input type="checkbox"/>		
Certificate of Amendment	<input checked="" type="checkbox"/>	<input type="checkbox"/>		
Consent of existing partners	<input checked="" type="checkbox"/>	<input type="checkbox"/>		
<b>III. Not-for-Profit Corporations – <u>Article 28 Corporation</u></b>				
Corporation	<input checked="" type="checkbox"/>	<input type="checkbox"/>		
Certificate of Incorporation	<input checked="" type="checkbox"/>	<input type="checkbox"/>		
Certificate of Amendment	<input checked="" type="checkbox"/>	<input type="checkbox"/>		
Bylaws	<input checked="" type="checkbox"/>	<input type="checkbox"/>		
Board Resolution(s)	<input checked="" type="checkbox"/>	<input type="checkbox"/>		
Amendments to Bylaws	<input checked="" type="checkbox"/>	<input type="checkbox"/>		

**New York State Department of Health  
Certificate of Need Application**

**Schedule 15**

DOCUMENTATION	NA	Attached	Attachment number	Electronic Document file name
<b>III. Not-for-Profit Corporations – <i>Proposed Active Member Corporation</i></b>				
Certificate of Incorporation	<input checked="" type="checkbox"/>	<input type="checkbox"/>		
Certificate of Amendment	<input checked="" type="checkbox"/>	<input type="checkbox"/>		
Bylaws	<input checked="" type="checkbox"/>	<input type="checkbox"/>		
Board Resolution(s)	<input checked="" type="checkbox"/>	<input type="checkbox"/>		
Amendments to Bylaws	<input checked="" type="checkbox"/>	<input type="checkbox"/>		
List of officers and directors	<input checked="" type="checkbox"/>	<input type="checkbox"/>		
<b>IV. Business Corporations</b>				
List regarding each incoming stockholder	<input checked="" type="checkbox"/>	<input type="checkbox"/>		
Evidence of transfer of stock	<input checked="" type="checkbox"/>	<input type="checkbox"/>		
Certificate of Incorporation	<input checked="" type="checkbox"/>	<input type="checkbox"/>		
Bylaws	<input checked="" type="checkbox"/>	<input type="checkbox"/>		
Board Resolution	<input checked="" type="checkbox"/>	<input type="checkbox"/>		
List of all stockholders (before and after)	<input checked="" type="checkbox"/>	<input type="checkbox"/>		
Transfer affidavits	<input checked="" type="checkbox"/>	<input type="checkbox"/>		
<b>V. Limited Liability Companies</b>				
List regarding each incoming member	<input type="checkbox"/>	<input checked="" type="checkbox"/>	Schedule 3 Attachment	
Evidence of transfer of membership interest	<input type="checkbox"/>	<input checked="" type="checkbox"/>	Schedule 3 Attachment	
Articles of Organization	<input type="checkbox"/>	<input checked="" type="checkbox"/>	Schedule 3 Attachment	
Operating Agreement, including documentation by incoming member(s).	<input type="checkbox"/>	<input checked="" type="checkbox"/>	Schedule 3 Attachment	
List of all members (before and after)	<input type="checkbox"/>	<input checked="" type="checkbox"/>	Schedule 3 Attachment	
Consent of existing members	<input type="checkbox"/>	<input checked="" type="checkbox"/>	Schedule 1 Attachment	

**Schedule 17 A - Diagnostic and Treatment Center Program Information.**

See "Schedules Required for Each Type of CON" to determine when this form is required.

**Instructions:** In the space below, briefly indicate how the facility intends to comply with state and federal regulations. If the application involves conversion of an existing practice, state who owns the practice and how the conversion will be done. If there are other entities utilizing the same space or resources, please state exactly how the space and resources will be allocated. Also, provide a description of the other entities.

The Center is in compliance with all State and Federal regulations. Since its inception, State Department of Health audits and facility inspections have resulted in no significant findings. The Center has proper protocols, oversight, process improvement and quality assurance measures in place to monitor continued compliance with all regulations. The Center is open five (5) days per week, Monday through Friday, 6:30 a.m. to 4:30 p.m.

The Center leases space at 60 Maple Road, Williamsville (Erie County), New York 14221 and is solely used by Endoscopy Center of Western New York, LLC. The extension clinic will be located at 250 Windward Road, Suite 140, Orchard Park (Erie County), New York 14127, and will implement the same policies and procedures as the main site. Please refer to the Schedule 17 Attachment for a statement confirming that the extension clinic will be located in separate and distinct space.

For D&TC - Ambulatory Surgery Projects:  
Please provide a list of ambulatory surgery categories you intend to provide.

Existing single-specialty (gastroenterology) freestanding ambulatory surgical center (FASC). No change is proposed in this application.

For D&TC -Ambulatory Surgery Projects:  
Please provide the following information:

Number and Type of Operating Rooms:

- Current:
- To be added:
- Total ORs upon Completion of the Project:

Number and Type of Procedure Rooms:

- Current: **5**
- To be added: **3**
- Total Procedure Rooms upon Completion of the Project:  
**Eight (8) (including three [3] at the extension clinic)**

**Schedule 17 B - Community Need**

See "Schedules Required for Each Type of CON" to determine when this form is required.

**Public Need Summary:**

Briefly summarize on this schedule, why the project is needed. Use additional paper, as necessary. If the following items have been addressed in the project narrative, please cite the relevant section and pages.

1. Identify the relevant service area (e.g., Minor Civil Division(s), Census Tract(s), street boundaries, Zip Code(s), Health Professional Shortage Area (HPSA) etc.)

Please see the Schedule 1 Attachment for the Project Narrative.

2. Provide a quantitative and qualitative description of the population to be served. (Qualitative data may include median income, ethnicity, payor mix, etc.)

Please see the Schedule 1 Attachment for the Project Narrative.

3. Document the current and projected demand for the proposed services. If the proposed services are covered by a DOH need methodology, demonstrate how the proposed service is consistent with it.

Please see the Schedule 1 Attachment for the Project Narrative.

4. (a) Describe how this project responds to and reflects the needs of the residents in the community you propose to serve.

Please see the Schedule 1 Attachment for the Project Narrative.

- (b) Describe how this project is consistent with your facility's Community Service Implementation Plan (voluntary not-for-profit hospitals) or strategic plan (other providers).

Please see the Schedule 1 Attachment for the Project Narrative.

- (c) Will the proposed project serve all patients needing care, regardless of their ability to pay or the source of payment? If so, please provide such a statement.

Please see the Schedule 1 Attachment for the Project Narrative.

5. Describe where and how the population to be served currently receives the proposed services.

Please see the Schedule 1 Attachment for the Project Narrative.

**ONLY For Applicants Seeking Permanent Life N/A**

**Diagnostic and Treatment Centers seeking approval for a Permanent Life MUST provide the following information:**

**Instructions:** In the space below, please provide detailed information on the **most recent CON application** that was approved for the limited life.

- i. CON number:
- ii. Date of approval:
- iii. Number of years of limited life approved for:
- iv. OpCert number and dates:
- v. Please provide a table with information on projections by payor for year 1 and year 3 **as reported on the approved CON**. (Please identify the projections in terms of **visits or procedures**).
- vi. Please provide a table with information on actual utilization by payor for each year since the implementation of the approved CON.  
  
**Note:** Please use the same category of payors for actual utilization as those used for projections in item 'v' above. Also, use the same category (i.e., **visits or procedures**) for actual utilization as those used for projections in item 'v' above.
- vii. Did you achieve those projections reported in item 'v' above?  
If not, please give reasons for not meeting those projections.  
How do you plan to improve this shortfall?

**Quality and Accreditation:**

1. Please cite relevant accreditations, certifications or awards attained by the applicant which build confidence in services of high quality. Examples include certification as a Federally Qualified Neighborhood Health Center.

The Center's existing program of ambulatory surgical services is already accepted by the community as providing high-quality, efficient and effective care to the residents of the service area. The Center is accredited by the Accreditation Association for Ambulatory Health Care (AAAHC).

2. Describe relevant programs or resources the applicant will bring to the new facility. Include existing programs that have proven track records at the applicant's other sites, if applicable, as well as programs the applicant plans for the future. Such programs include:
  - a. Programs specially tailored to the health needs of the population of the service area.
  - b. Grant funded programs.

- c. Scholarships or fellowships.

The Center's evolving strategic plan is to continue providing surgical services in the underserved community in which it operates, consistent with the New York State and Federal government initiatives promoting wellness, prevention and access. The Center's goals include quality and access to the residents of the Erie County community that it serves.

- 3. Describe the applicant's experience or track record serving similar populations:

Please see the Schedule 1 Attachment for the Project Narrative.

**Primary and Specialty Care Services Review Criteria: N/A  
Expansion of Services**

When a CON application proposes conversion of a group or solo medical practice to Article 28 status, the applicant must provide a written analysis of the effect of the proposal on the following factors:

- 1. The full time equivalent (FTE) number of primary care physicians and specialists, by specialty, engaged in the practice after the conversion compared with the number before conversion.

- 2. The (FTE) number of non-physician providers of primary care and specialty care, by specialty, such as Physician Assistants, Certified Nurse Practitioners, Physical Therapists, and Dental Assistants after the conversion compared with the number before conversion.

- 3. The number of primary care and specialty visits, by specialty, after the conversion compared with the number before conversion.

- 4. The array of services to underserved clients after the conversion compared with the number before conversion.

**Target Population and Service Area: N/A**

All applications involving primary care services must provide a written analysis that clearly demonstrates that the proposal meets at least one of the following criteria. For criteria that do not apply, enter "not applicable":

- 1. The proposed clinic is in an underserved area as indicated by location in a Health Professional Shortage Area (HPSA) or Medically Underserved Area (MUA).

- 2. The population to be served exhibits poor health status, as measured by factors such as high levels of inpatient discharges for ambulatory care sensitive conditions (ACSC), incidences of diseases and conditions in excess of standards in Healthy People 2010 or other pertinent indicators.



3. The primary care services of the proposed clinic will be targeted to a group or population with special needs or conditions that make it difficult for them to obtain adequate primary care in clinics or physician practices serving the general population. Examples of such needs and conditions are:
- Developmental disabilities.
  - HIV.
  - Alcohol Substance Abuse.
  - Health needs relating to aging.
  - Mental Health needs.
  - Homelessness
  - Linguistic or cultural barriers in obtaining access to primary care.

**Capacity of Existing Primary Care Providers N/A**

The project narrative should describe existing primary care services in the proposed service area. The narrative should include the number and location of existing D&TCs, extension clinics and part-time clinics and a summary of primary care services available through private practices. The narrative should indicate whether travel time and transportation are factors in access to primary care. Examples of travel related issues include topography, seasonal weather conditions, and availability of public transportation. Applicants are not expected to describe the volume of services delivered by existing providers, since they will rarely have access to such data, but the project narrative should indicate that the applicant is reasonably familiar with the overall availability of primary care in the targeted area.

In instances where the target area is likely to already have significant primary care resources, the CON proposal will be reviewed for the following need related factors:

- The ratio of primary care physicians to population in the proposed service area. HPSA uses a ratio of 1.0 FTE physicians to 3000 persons; Medicaid Managed Care uses a ratio of 1 to 1500.
- The number of primary care physicians in the proposed service area who are "active" in serving the Medicaid population. This is often measured as physicians who are reimbursed \$5000 or more per year by Medicaid.
- The annual number of primary care visits per person by Medicaid eligible persons in the proposed service area. An average lower than 2.0 visits per person is often considered a problem.
- The percentage of the Medicaid population that is enrolled in Managed care will be taken into account where appropriate.
- The current volume of primary care visits to existing D&TC and Extension clinics.

Not all of the above criteria need be evaluated for all applications. The number will vary depending on the type and location of services proposed and on how thoroughly the application addresses need in the project narrative and the related schedules.

**Need Review for Specialty Clinics:**

Applications not involving primary care services must also provide a written analysis that clearly demonstrates that the need exists for the proposed services

4. Is the proposed clinic in an underserved area as indicated by location in a Health Professional Shortage Area (HPSA) or Medically Underserved Area (MUA)?

The Center and the proposed extension clinic are not located in a Health Professional Shortage Area (HPSA) or a Medically Underserved Area (MUA).

**New York State Department of Health  
Certificate of Need Application**

**Schedule 17B**

5. Describe in very specific terms the patients who require the specialty services, including the number of patients and their specific health problems, and how the proposed facility will meet their needs better than existing providers.

Please see the Schedule 1 Attachment for the Project Narrative.

6. In the case of Dental clinics, is the application supported by the local Health Department? Is the proposal supported by the Department of Health's Bureau of Dental Services? Is the applicant participating in current dental health initiatives? Has the applicant consulted with resources such as the New York State Oral Health Technical Assistance Center?

N/A

**New York State Department of Health  
Certificate of Need Application**

**Schedule 17C**

**Impact of Proposed CON on Diagnostic & Treatment Center Operating Certificate**

The Sites Tab in NYSE-CON has replaced the Authorized Beds and Services Tables of Schedule 17C. The Authorized Beds and Services Tables in Schedule 17C are only to be used when submitting a Modification, in hardcopy, after approval or contingent approval.

**TABLE 17C-1 AUTHORIZED CERTIFIED SERVICES NOT APPLICABLE**

**Instructions:**  
For applications requesting changes to more than one location, complete a separate Table 17-C-1 for each location

LOCATION: <i>(Enter street address of facility)</i>	<input type="checkbox"/> <b>MOBILE CLINIC DESIGNATION (217)</b> Check box only if extension clinic is mobile <i>(A mobile clinic must be an extension clinic with a fixed main site)</i>			
	Existing	Add	Remove	Proposed
MEDICAL SERVICES – PRIMARY CARE <sup>6</sup>	<input type="checkbox"/>	<input type="checkbox"/>	<input type="checkbox"/>	<input type="checkbox"/>
MEDICAL SERVICES – OTHER MEDICAL SPECIALTIES	<input type="checkbox"/>	<input type="checkbox"/>	<input type="checkbox"/>	<input type="checkbox"/>
ABORTION	<input type="checkbox"/>	<input type="checkbox"/>	<input type="checkbox"/>	<input type="checkbox"/>
ADULT DAY HEALTH - AIDS	<input type="checkbox"/>	<input type="checkbox"/>	<input type="checkbox"/>	<input type="checkbox"/>
AMBULATORY SURGERY				
MULTI-SPECIALTY <sup>8</sup>	<input type="checkbox"/>	<input type="checkbox"/>	<input type="checkbox"/>	<input type="checkbox"/>
SINGLE SPECIALTY – GASTROENTEROLOGY <sup>8</sup>	<input type="checkbox"/>	<input type="checkbox"/>	<input type="checkbox"/>	<input type="checkbox"/>
SINGLE SPECIALTY – OPHTHALMOLOGY <sup>8</sup>	<input type="checkbox"/>	<input type="checkbox"/>	<input type="checkbox"/>	<input type="checkbox"/>
SINGLE SPECIALTY – ORTHOPEDICS <sup>8</sup>	<input type="checkbox"/>	<input type="checkbox"/>	<input type="checkbox"/>	<input type="checkbox"/>
SINGLE SPECIALTY – PAIN MANAGEMENT <sup>8</sup>	<input type="checkbox"/>	<input type="checkbox"/>	<input type="checkbox"/>	<input type="checkbox"/>
SINGLE SPECIALTY -- OTHER (SPECIFY) <sup>8</sup>	<input type="checkbox"/>	<input type="checkbox"/>	<input type="checkbox"/>	<input type="checkbox"/>
BIRTHING SERVICE O/P	<input type="checkbox"/>	<input type="checkbox"/>	<input type="checkbox"/>	<input type="checkbox"/>
CERTIFIED MENTAL HEALTH O/P <sup>1</sup>	<input type="checkbox"/>	<input type="checkbox"/>	<input type="checkbox"/>	<input type="checkbox"/>
CHEMICAL DEPENDENCE - REHAB <sup>2</sup>	<input type="checkbox"/>	<input type="checkbox"/>	<input type="checkbox"/>	<input type="checkbox"/>
CHEMICAL DEPENDENCE - WITHDRAWAL O/P <sup>2</sup>	<input type="checkbox"/>	<input type="checkbox"/>	<input type="checkbox"/>	<input type="checkbox"/>
CLINIC PART TIME SERVICES	<input type="checkbox"/>	<input type="checkbox"/>	<input type="checkbox"/>	<input type="checkbox"/>
CT SCANNER	<input type="checkbox"/>	<input type="checkbox"/>	<input type="checkbox"/>	<input type="checkbox"/>
DENTAL O/P	<input type="checkbox"/>	<input type="checkbox"/>	<input type="checkbox"/>	<input type="checkbox"/>
HOME HEMODIALYSIS TRAINING AND SUPPORT <sup>4</sup>	<input type="checkbox"/>	<input type="checkbox"/>	<input type="checkbox"/>	<input type="checkbox"/>
HOME PERITONEAL DIALYSIS TRAINING AND SUPPORT <sup>4</sup>	<input type="checkbox"/>	<input type="checkbox"/>	<input type="checkbox"/>	<input type="checkbox"/>
INTEGRATED SERVICES – MENTAL HEALTH	<input type="checkbox"/>	<input type="checkbox"/>	<input type="checkbox"/>	<input type="checkbox"/>
INTEGRATED SERVICES – SUBSTANCE USE DISORDER	<input type="checkbox"/>	<input type="checkbox"/>	<input type="checkbox"/>	<input type="checkbox"/>
LITHOTRIPSY O/P	<input type="checkbox"/>	<input type="checkbox"/>	<input type="checkbox"/>	<input type="checkbox"/>
MAGNETIC RESONANCE IMAGING (MRI)	<input type="checkbox"/>	<input type="checkbox"/>	<input type="checkbox"/>	<input type="checkbox"/>
METHADONE MAINTENANCE O/P	<input type="checkbox"/>	<input type="checkbox"/>	<input type="checkbox"/>	<input type="checkbox"/>
RADIOLOGY – THERAPEUTIC O/P <sup>5</sup>	<input type="checkbox"/>	<input type="checkbox"/>	<input type="checkbox"/>	<input type="checkbox"/>
RENAL DIALYSIS, CHRONIC [Complete the ESRD section 17C-1(a)&(b) below] <sup>4</sup>	_____	_____	_____	_____
TRAUMATIC BRAIN INJURY PROGRAM O/P	<input type="checkbox"/>	<input type="checkbox"/>	<input type="checkbox"/>	<input type="checkbox"/>

<sup>1</sup> A separate licensure application must be filed with the NYS Office of Health in addition to this CON.  
<sup>2</sup> A separate licensure application must be filed with the NYS Office of Alcoholism and Substance Abuse Services in addition to this CON.  
<sup>4</sup> Require additional approval by Medicare  
<sup>5</sup> RADIOLOGY – THERAPEUTIC includes Linear Accelerators.  
<sup>6</sup> PRIMARY CARE includes one or more of the following: Family Practice, Internal Medicine, Ob/Gyn or Pediatric  
<sup>7</sup> Must be certified for Home Hemodialysis Training & Support

**New York State Department of Health  
Certificate of Need Application**

**Schedule 17C**

END STAGE RENAL DISEASE (ESRD) NOT APPLICABLE

<b>TABLE 17C-1(a) CAPACITY</b>	Existing	Add	Remove	Proposed
CHRONIC DIALYSIS				

If application involves dialysis service with existing capacity, complete the following table:

<b>TABLE 17C-1(b) PROCEDURES</b>	Last 12 mos	2 years prior	3 years prior
CHRONIC DIALYSIS			

All Chronic Dialysis applicants must provide information requested on the following page in compliance with 10 NYCRR 670.6.

END STAGE RENAL DISEASE NOT APPLICABLE

1. Provide a five-year analysis of projected costs and revenues that demonstrates that the proposed dialysis services will be utilized sufficiently to be financially feasible.

2. Provide evidence that the proposed dialysis services will enhance access to dialysis by patients, including members of medically underserved groups which have traditionally experienced difficulties obtaining access to health care, such as; racial and ethnic minorities, women, disabled persons , and residents of remote rural areas.

3. Provide evidence that the hours of operation and admission policy of the facility will promote the availability of dialysis at times preferred by the patients, particularly to enable patients to continue employment.

4. Provide evidence that the facility is willing to and capable of safely serving patients.

5. Provide evidence that the proposed facility will not jeopardize the quality of care or the financial viability of existing dialysis facilities. This evidence should be derived from analysis of factors including, but not necessarily limited to current and projected referral and use patterns of both the proposed facility and existing facilities. A finding that the proposed facility will jeopardize the financial viability of one or more existing facilities will not of itself require a recommendation to of disapproval.

**New York State Department of Health  
Certificate of Need Application**

**Schedule 17C**

**Table 17C-2 - Projected Utilization of Services:**

The number of projected "visits" should be listed in this table for each existing or proposed certified service. Visits should be estimated for the current, first and third year of the project. This table should contain visit estimates for services at this site alone, not for the applicant's other sites.

	Current Year Visits*	First Year Visits*	Third Year Visits*
<b>CERTIFIABLE SERVICES</b>			
MEDICAL SERVICES – PRIMARY CARE			
MEDICAL SERVICES – SPECIALTIES			
ABORTION			
ADULT DAY HEALTH - AIDS			
AMBULATORY SURGERY – GASTROENTEROLOGY	16,967	25,698	26,224
AMBULATORY SURGERY – OPHTHALMOLOGY			
AMBULATORY SURGERY – ORTHOPEDICS			
AMBULATORY SURGERY -- PAIN MANAGEMENT			
AMBULATORY SURGERY – OTOLARYGOLOGY			
AMBULATORY SURGERY – UROLOGY			
AMBULATORY SURGERY -- MULTI-SPECIALTY			
BIRTHING SERVICE O/P			
CLINIC PART TIME SERVICES			
CLINIC SCHOOL BASED SERVICES			
CLINIC SCHOOL BASED DENTAL PROGRAM			
CT SCANNER			
DENTAL O/P			
HOME HEMODIALYSIS TRAINING AND SUPPORT			
HOME PERITONEAL DIALYSIS TRAINING AND SUPPORT			
INTEGRATED SERVICES – MENTAL HEALTH			
INTEGRATED SERVICES – SUBSTANCE USE DISORDER			
LITHOTRIPSY O/P			
MAGNETIC RESONANCE IMAGING (MRI)			
METHADONE MAINTENANCE			
RADIOLOGY – THERAPEUTIC			
RENAL DIALYSIS, CHRONIC			
TRAUMATIC BRAIN INJURY PROGRAM O/P			
UPGRADED DTC SERVICES			
<b>OTHER SERVICES</b>			
<b>Total</b>	16,967	25,698	26,224

\* The 'Total' reported MUST be the SAME as those on Table 13D-4

**ENDOSCOPY CENTER OF WESTERN NEW YORK, LLC**

**SCHEDULE 17 ATTACHMENT**

**Separate and Distinct Statement**

## SEPARATE AND DISTINCT STATEMENT

### Applicant Affirmations:

- The applicant affirms that the extension clinic will be located in a self-contained space located at 250 Windward Road, Suite 140, Orchard Park (Erie County), New York 14127. The extension clinic will have a dedicated entrance and will have full physical separation from any other entities at the location. Please refer to the floor plan under the Schedule 6 Attachment.
- The applicant will put in place signage which will denote that the extension clinic is separate and distinct from any other entity in the building. This will be accomplished by clearly identifying the operations of the extension clinic with its logo and signage.
- The applicant affirms that staffing for the extension clinic will be separate and distinct from any other entity at the location and will be dedicated to the extension clinic's function during its hours of operation.
- The applicant affirms that the extension clinic will be used exclusively for the purposes stated throughout this application.